

Production Program

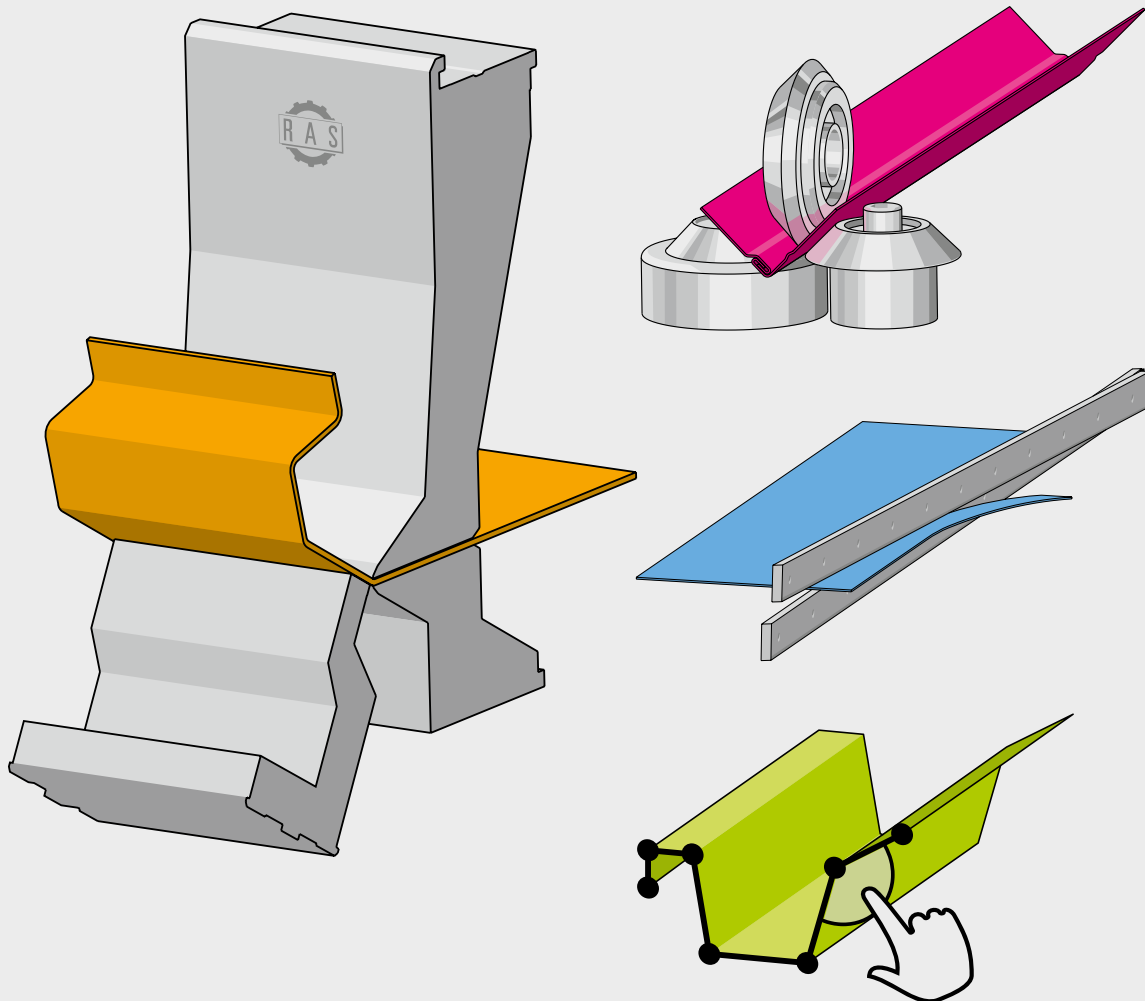

CUTTING

BENDING

FORMING

SOFTWARE

RAS 25.15

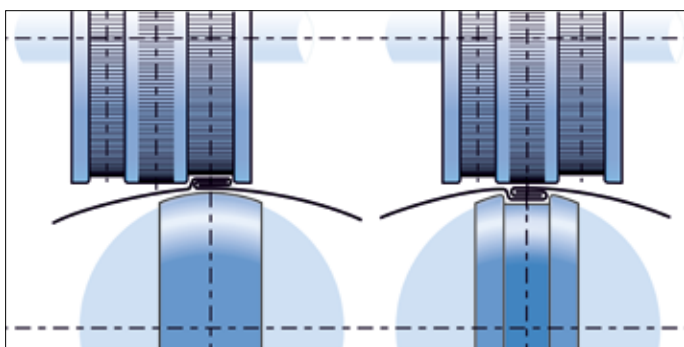

For closing inside and outside seams on round pipe.



Technical data	Sheet thickness max.	Working length	Shaft diameter
RAS 25.15-2	0.88 mm	1520 mm	90 mm

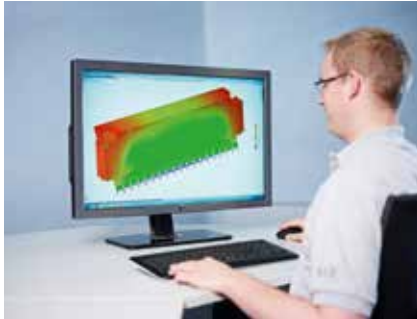

Design



Sawing



Plasma cutting



Milling



Turning



Grinding



Welding



Powder coating



Assembly



Electrical assembly



Quality inspection



RAS - Regional production for global sustainability



Headquarters in Sindelfingen. In the foreground „Steel object“.



Effringen - factory and artwork



RAS Systems LLC in Georgia, USA



Founder Wilhelm Reinhardt



Managing Directors Rainer Stahl, Matthias Huber und Willy Stahl

All sheet thickness refer to 400 N/mm²
tensile strength. Subject to changes.
Pictures may show options.