

■ ABM-30 | AUTO TRAVEL TRACKLESS BEVELLER

The ABM-30 portable beveling machine performs auto travel beveling on steel plates on top, face and bottom edges. The beveller needs no track to move along steel plate to produce accurate high-quality double-side bevels without thermal distortion or creation of heat affected zone on plate thickness range 8-60 mm.

The ABM-30 features an infinitely adjustable bevel angle between - 70 and + 70 degrees and is capable of producing bevels up to 30 mm wide.

It also allows for facing in both directions with the milling head depth of 1 mm.

■ Features and benefits:

- 4-wheel drive eliminates a need for guide track
- self-propelled machine for consistent bevel geometry from edge-to-edge
- control panel indicates current work mode and gives safety and diagnostic information
- capable of producing bevels up to 30 mm wide
- infinite bevel angle adjustment from -70 to +70 degrees is quick and user-friendly
- variable spindle speed
- produces double-side bevels without having to flip the plate enhancing safety and reducing material handling time and expense
- feedback-controlled overload system to prevent motor damage
- semi-automatic drive stop at plate end
- plate thickness up to 60 mm



Top beveling



Bottom beveling



Facing-off

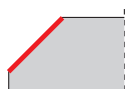

Top beveling



Facing off



Bottom beveling



Plate thickness
max 60 mm

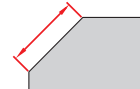

Bevel width
up to 30 mm



Bevel angle
between -70 and 70°

ABM-30 TECHNICAL SPECIFICATION	
Voltage	1~ 200-240 V, 50/60 Hz 1~ 110-120 V, 50/60 Hz
Power	2200 W
Spindle rotational speed (without load)	1800-5850 rpm
Feed speed	0-2 m/min (0-6.5 ft/min)
Bevel angle (β , Fig. 1)	From -70° to 70°
Maximum bevel width (b, Fig. 1)	30 mm (1.18")
Sheet thickness	8-60 mm (0.3-2.3")
Required ambient temperature	5-40°C
Weight	43 kg (94.8 lbs)
Product Code	UKS-0690-10-00-00-0



Control panel indicates current work mode and gives safety and diagnostic information



Precise bevel angle setting

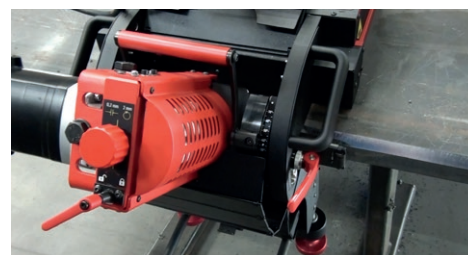

Innovative and ergonomic bevel angle adjustment system with release lever requires no additional tools



Convenient adjustment to plate thickness

Control panel

- Feed direction indication
- Material detection
- Bar graph for motor load illustration
- Visual warning signals

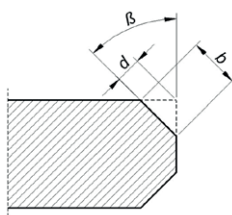

Shipping set:

- Beveling machine (with a milling head and 5 cutting inserts)
- Tool box
- Drift
- 10 mm hex wrench
- 3 mm hex wrench
- 8 mm combination wrench
- Grease for screws Molykote 1000 (5 g, 0.17 oz)
- Operator's Manual

β	b
0°	30 mm (1.18")
15°	30 mm (1.18")
37.5°	30.5 mm (1.2")
45°	30 mm (1.18")
60°	30 mm (1.18")
70°	31 mm (1.22")

Accessories:



ZST-0715-23-00-00-0
Milling head for stainless steel



PLY-000849
Cutting insert for stainless steel (sold 10 pcs/box)



WKR-000592
Insert fixing screw for stainless steel

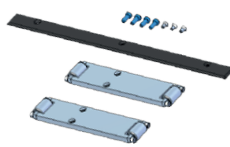

ZST-0690-16-00-00-0
Set for stainless steel for ABM-30



GLW-0715-19-00-00-0
Milling head



PLY-000756
Cutting insert (sold 10 pcs/box)



WKR-000577
Insert fixing screw



WOZ-0690-20-00-00-0
Screw type transportation and storage trolley with stepless height adjustment



WOZ-0690-30-00-00-0
Column type transport and storage trolley with adjustable height in 15 mm increments

Dimensions:

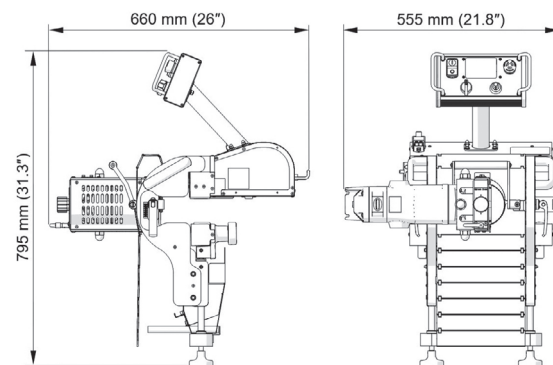

PROMOTECH Sp. z o.o.
Elewatorska 23/1
15-620 Białystok, POLAND
Phone +48 85 678 34 05
sales@promotech.eu



Your local dealer:

