

PROMOTECH[®]

AUTOMATION

CB WELDING (TIG/PLASMA/MIG/SAW)



3D PROFILE CUTTING



GANTRY WELDING SYSTEMS



3D CUTTING & WELDING (SAW)



**Industrial
Solutions**

CUTTING & WELDING

CATALOGUE

PROMOTECH – PROFESSIONAL MANUFACTURER OF PREMIUM MACHINES FOR METALWORKING INDUSTRY

PROMOTECH is an innovation driven ISO 9001:2015 manufacturer of professional metalworking machines, welding automation equipment and industrial systems designed for structural steel fabricators, heavy machinery manufacturers, shipyards and other metal machining companies

Main product lines:

- mag drills, pneumatic drills, rail drills and hydraulic punchers
- weld preparation/portable and stationary bevellers for plates and pipes
- welding and cutting portable mechanisation equipment
- welding and cutting automated systems

Our products:

- offer solutions to reduce cost and increase productivity
- are designed and engineered for long term use in tough industrial conditions
- meet the requirements of the most demanding clients and markets worldwide
- are made in Poland according to the highest quality standards
- include top quality components
- are thoroughly tested for quality approval
- proved to be extremely reliable with a variety of practical applications in most difficult climatic environments



FOLLOW US FOR UPDATE AND MORE

PROMOTECH

PIPE PROFILE CUTTING MACHINE

PPCM 1500

www.promotech.eu

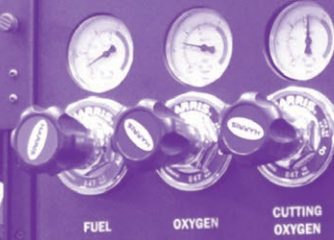

TABLE OF CONTENT

	<i>PAGE</i>
COLUMN & BOOMS	4
WA 1000/1500/2000	8
MOPS	12
WA COMPACT	14
PPCM 650	16
PPCM 1500	18
MCM 1000/MINI	22
MCM 4000 S/ XW/ TW/ 4500	24
SWSO	28
PREMIUM POSITIONERS	31
STANDARD POSITIONERS	32
JTS	36
WIRE FEEDER BOOMS	38
RWCA	42

CUTTING & WELDING

www.promotech.eu



CUTTING AND WELDING AUTOMATION



COLUMN & BOOMS

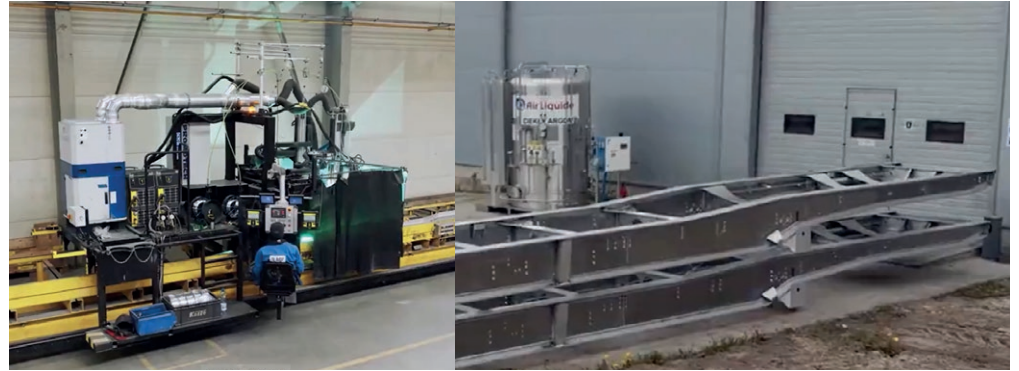

GWS WA 1500 HD / WA 2000 HD & MULTI AXIS JOINT TRACKING SYSTEM

PIPE PROFILE CUTTING MACHINE



PPCM 650

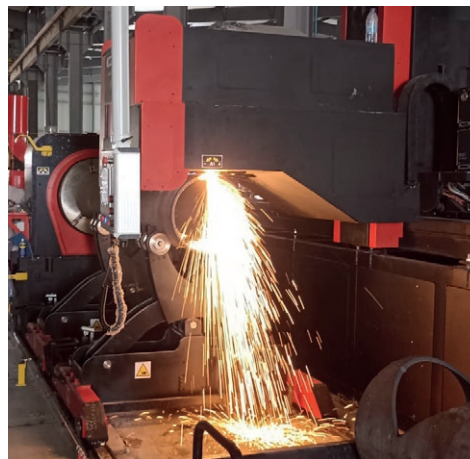

PPCM 1500



JTS - AUTOMATIC JOINT TRACKING SYSTEM (STAND ALONE)



MCM 1000/4000/4500 5 AXIS PORTABLE CNC CUTTING AND WELDING MACHINE



ROBOTIZED WELDING/CUTTING ARM

All information is subject to change without notice 26.05

CUTTING AND WELDING AUTOMATION



WELDING WORKSTATIONS

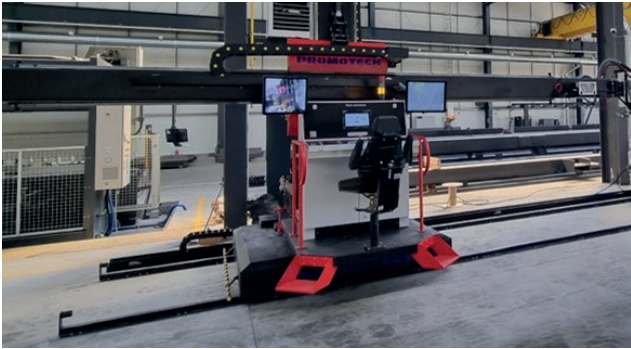

C&B | COLUMN & BOOMS

Promotech manufactures wide range of customized column and booms.

Depends on the request column and booms will be delivered with SAW SINGLE OR TANDEM, MIG/MAG, TIG or PLASMA welding head and selected optional items like welding positioners, rotators, fit up bed rollers/turning rolls.

24 months extended warranty.



CRYOGENIC
TANK



QUALITY CHECK
- NO WELDING
DEFECTS



MIG WELDING



TIG WELDING



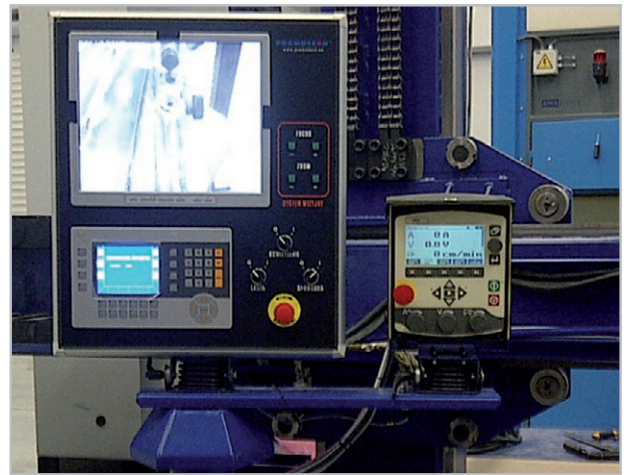

Sample view of C&B operating panel and integrated SAW ACDC welding equipment from (Lincoln Electric and ESAB)



Sample view of C&B operating panel and integrated MIG-MAG welding equipment from (ESAB and LORCH)



Optional equipment include: camera system for GMAW/SAW, automatic joint tracking system, flux handling equipment, fume extraction, welding rotators, positioners and turntables.

Welding process START/STOP available from one C&B control operating panel.

All our column and booms are equipped with passive safety systems such as safety chains, automatic brakes on a gear motor in case of power failure.

Active safety systems such as limit switches to prevent collisions are also standard.



Standard and customized C&B by sample succesfull deliveries

Applications for welding of long structural beams of closed profile, beams type T, H, HSI, HSQ with web height up to 1500 mm and the inside/outside welding of tanks, pressure vessels.



Sample views of C&B workstations.

Optional equipment: welding positioners and rotators available from PROMOTECH Automation



Customized applications delivered to our Clients by sample



ABM-50 for high-quality single and double-sided bevels



C&B TIG/MIG-MAG and SAW READY

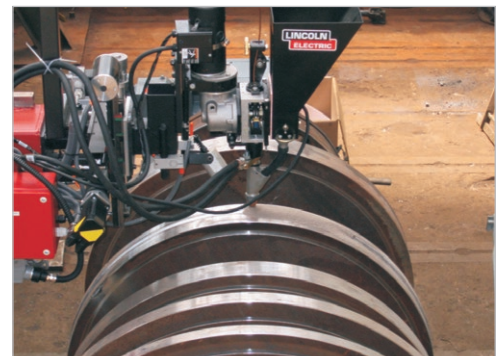

Hard-surfacing of turbines

Column and booms can be integrated with other equipment working in the system such as roller beds or other welding positioners.

Column and booms can be customized according to individual Client request.

WA 1000/1500/2000

MIG-MAG / SAW
SD / HD

Automatic longitudinal top quality MIG-MAG or SAW welding of long structural Box beams and H, I, T, HKS, HSQ also automotive chassis for long truck/train beams.

Single or multi-pass automatic fillet/butt welding with mechanical-electro joint tracking system.

Minimized welding defect&reduced non-productive time and it's **One-man operation!**

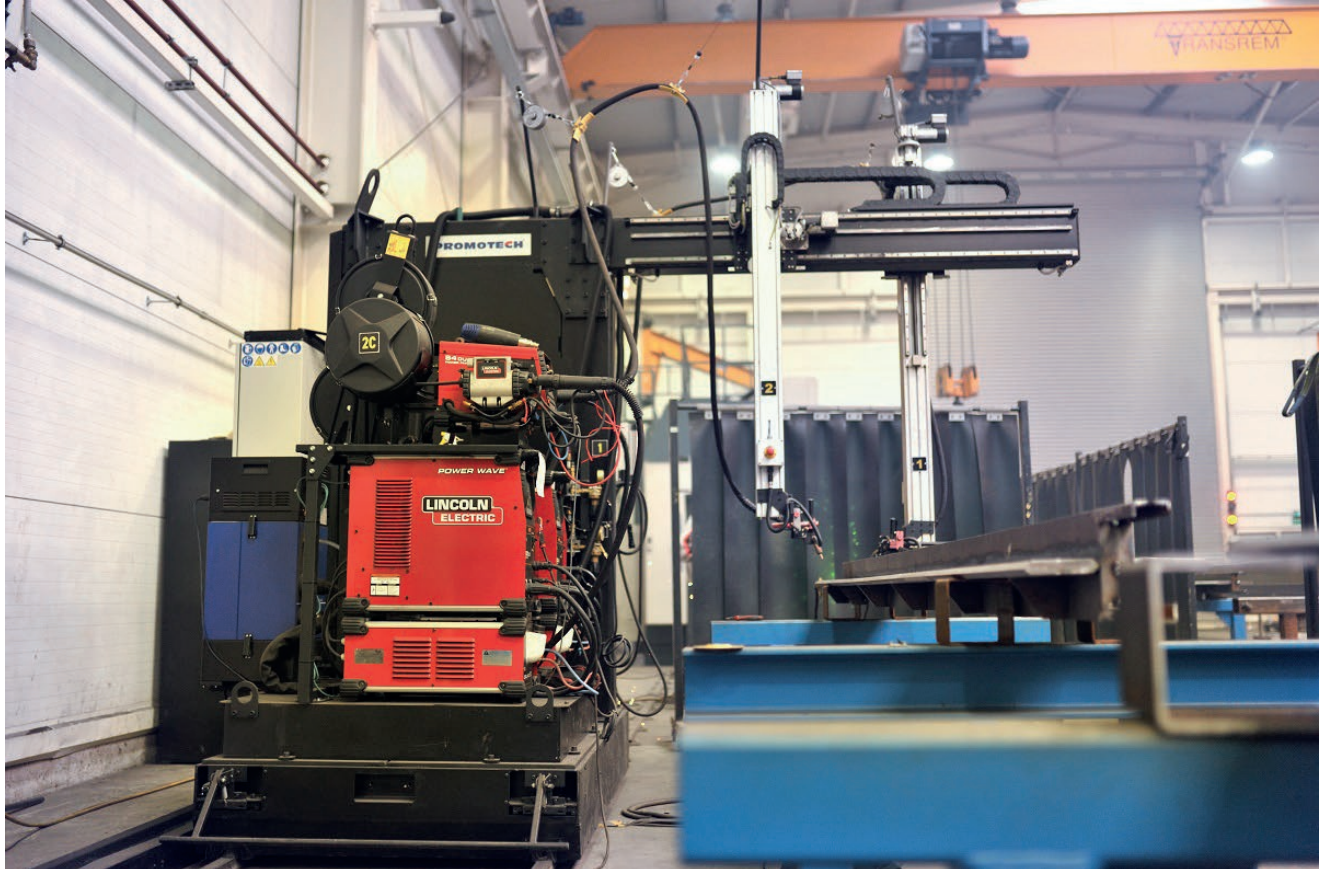

GWS type WA TWIN MIG (Hyperfill)

Your benefits:

- Automatic fillet and butt welding with joint tracking
- Multipass welding
- One-man operation
- Reduction of costly over-welding and decrease in filler metal usage
- User friendly interface – multiple languages
- Accepts most of MIG-MAG and SAW welding power sources
- 24 months extended warranty

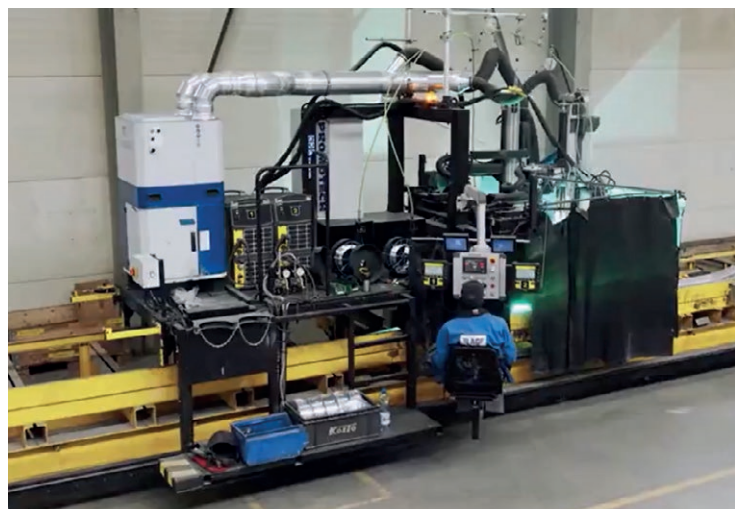

Promotech automatic mechanical-electro joint tracking ensure proper and repeatable torch positioning / welding process.

TECHNICAL SPECIFICATIONS	WA 1000 SD / WA 1500 SD
Welding method	MIG/MAG
Welding Torch Rotation Module (MOPS)	Option
Length of track	13m / 12m 16m/15m 19m/18m Upon request 19m+
Max workpiece height	1m (39.4") / 1.5m (60")
Max welding speed	Up to 2 m/min solid wire
Possibility to implement additional functionality e.g. welding length, intermittent welds	Yes
Possibility of changing welding parameters during welding process "on the fly"	Option
Fume extraction system (recommended)	Recommended Option for Operator safety

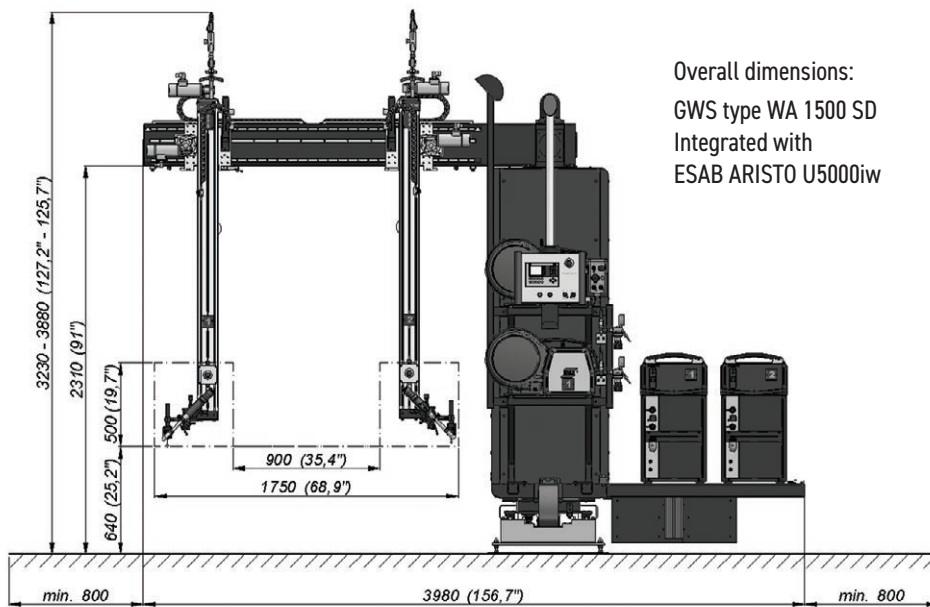
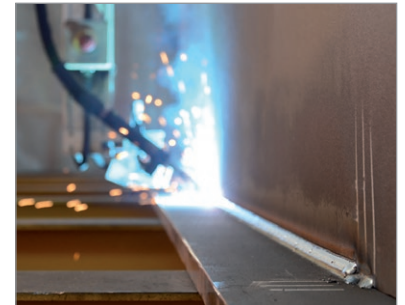
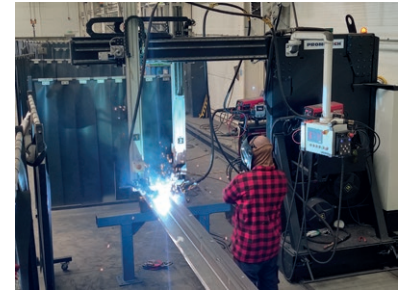

GWS type WA work-station applications confirmed with customers in automotive and steel construction business.



Purpose designed and custom built versions to be agreed with Promotech.

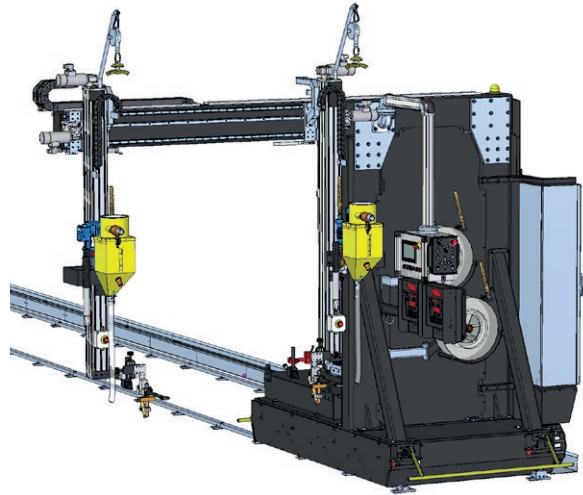
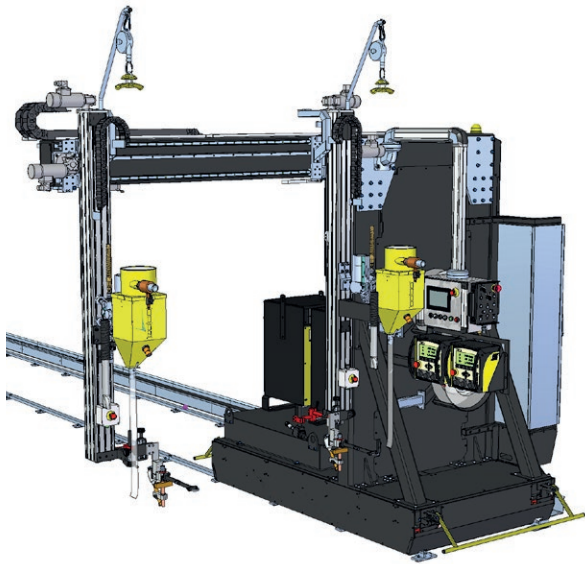

View of GWS type WA 1500 HD / WA 2000 HD MAG/SAW (CV or CC).

TECHNICAL SPECIFICATIONS FOR GWS TYPE WA 1500 HD / WA 2000 HD	
Welding method	either SAW or MIG/MAG
Basic flux recovery system (gravity)	Option
Advanced flux handling system	Option
Welding Torch Rotation Module (MOPS)	Option
Fume extraction system (recommended)	Option
Length of track	Up to 30 m
Max workpiece height	Up to 2 m (80")
Max welding speed	Up to 2 m/min. solid wire
Possibility to implement additional functionality e.g. welding length, intermittent welds	Yes
Possibility of changing welding parameters during welding process "on the fly"	Option
Wire drum feeding	Option



Promotech automatic mechanical-electro joint tracking ensure proper and repeatable welding by means of easy slug removal process.

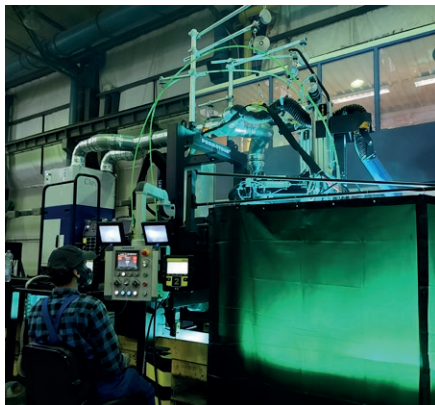

Special design machine for the trailer beam welding.



All GWS WA HD workstations are equipped with cameras to ensure an operator and welding process safety!

GWS WA work-stations accepts most of welding MIG-MAG and SAW power sources available in the market.

■ GWS type WA MIG / MAG
Integrated **LORCH S8**



■ GWS type WA MIG / MAG
Integrated **EWM Phoenix**



■ GWS type WA MIG / MAG
Integrated **LINCOLN ELECTRIC PW500 HYPERFILL**



■ GWS type WA MIG / MAG
Integrated **KEMPPI FASTMIG X 450**



■ GWS type WA MIG / MAG
Integrated **ESAB ARISTO U5000iw**



MOPS | WELDING TORCH ROTATION MODULE

Welding Torch Rotation Module (MOPS) for longitudinal welding of variable geometry chassis and structural beams.

Thanks to MOPS, the welding torch keeps a constant position relative to the workpiece, ensuring uniform weld quality along the entire length of the welded joint. The torch position in relation to the workpiece is determined by the distance in the vertical and horizontal axes, correct angle between the welding torch and the workpiece, and tilt angles of the torch. In addition, automatic torch rotation maintains a steady rake angle to the workpiece. Constant values of these parameters ensure proper penetration in depth and width of the weld face.

Welding portals equipped with MOPS are an attractive alternative to robotic applications and allow you to increase welding speed and significantly reduce operator training time.

The use of MOPS in the SAW process makes it possible to produce materials in excess of 4mm thick with minimal energy input, reducing workpiece deformation.

Torches with MOPS control easily handle shiny materials such as aluminum and high-alloy steel.



MIG / MAG, TWIN



SAW

Features and benefits:

- Designed to maintain automatically the constant position of the welding torch in relation to the seam during welding process
- Maximum taper angle (A): 20°
- Minimum width of the welded beam (h): 120 mm
- Maximum width of the welded beam (H): 1500 mm
- Minimum height of the beam flange (B): 90 mm
- Maximum height of the beam flange (B): 160 mm
- Type of weld and welding position: fillet weld, PB position
- Welding process type: MIG/MAG or SAW
- Welding torch to be advised
- Welding equipment to be advised
- 24 months extended warranty

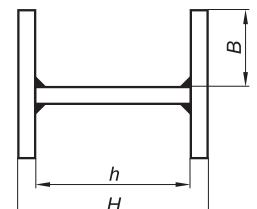
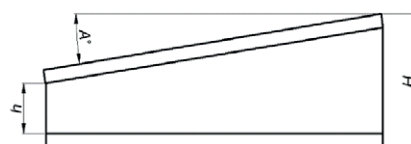
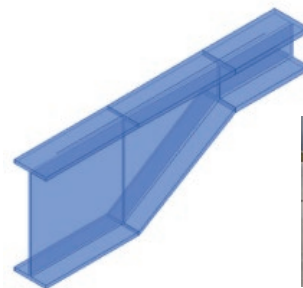

Welding Torch Rotation Module for WA (target industries):

- Automotive (e.g. truck chassis),
- Railways (e.g. wagon construction),
- Bridge construction,
- Building construction

Structural beam type welding

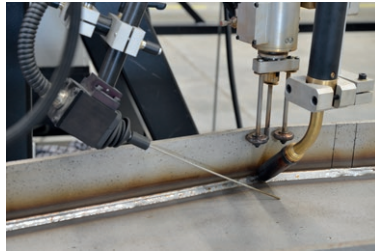
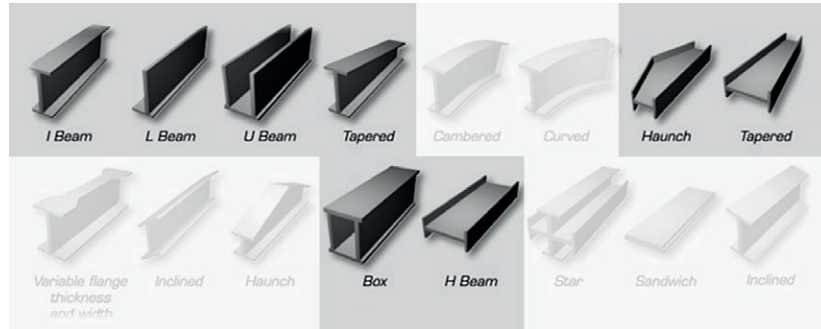

Automotive chassis beam type welding

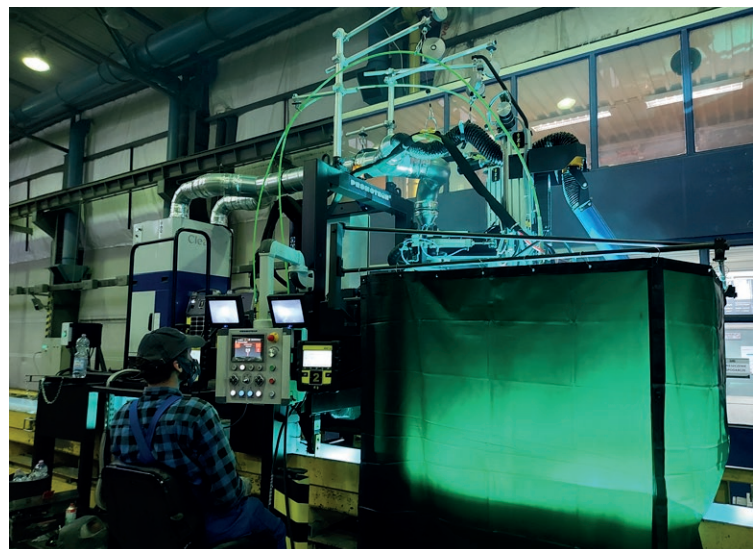

Special design machine for the trailer beam welding.

WA COMPACT | WELDING SYSTEM

The WA Compact Welding System is an advanced and versatile welding solution designed for making both continuous and stitch butt and fillet welds using the MIG/MAG method.

The system provides efficient joint tracking for active compensation of torch position vertically and horizontally with and without oscillation.

WA Compact supports welding with different oscillation patterns, including straight, triangle, trapezoid, and square, enhancing its adaptability to various welding tasks.

It is ideally suited for industrial applications, providing an efficient and budget-friendly option for workshops and large industrial plants.



Features and benefits:

- **Advanced Welding Capabilities:** Supports both continuous and stitch welding using MIG/MAG method, ensuring versatility in different welding tasks.
- **Precision and Efficiency:** Equipped with oscillation and joint tracking with motorized vertical slide, maintaining the correct torch position for high-quality welds.
- **Flexible Oscillation Patterns:** Offers various weld paths such as straight, triangle, trapezoid, and square, increasing adaptability to different requirements.
- **User-Friendly Control:** Ergonomic remote control pendant with simple and easy to find control knobs makes adjustments possible without lifting of the operator's welding hood.
- **Custom Track Length:** Track sections consists of 2 m support segments. The total length of the track can be tailored to the customer's requirements.
- **Cost-Effective Solution:** Budget-friendly advanced and versatile welding solution with customized workspace, making it a practical choice for both workshops and large industrial facilities.

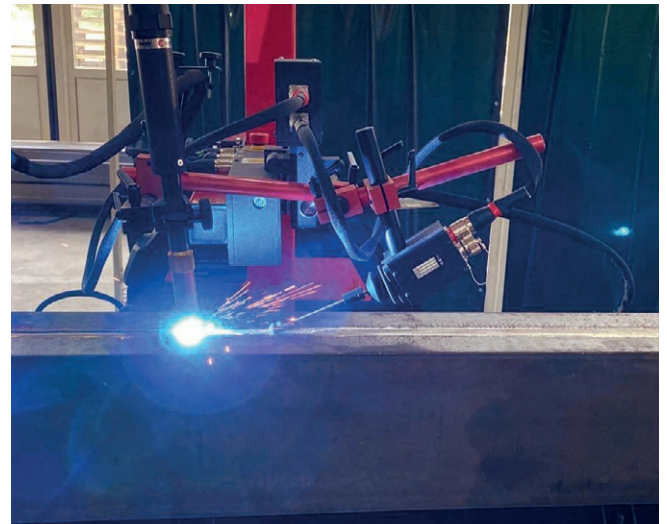

Welding joints:



WA COMPACT TECHNICAL SPECIFICATION

Voltage	1~ 110-120 V, 50-60 Hz 1~ 220-240 V, 50-60 Hz
Power	200 W
Torch type	MIG/MAG
MIG/MAG torch diameter	16-22 mm (5/8"-55/64")
Horizontal speed	0,05-2,5 m/min (2-98 inch/min)
Standard torch travel length *	3,5 m
Standard overall track length *	4 m
* Can be extended by a 2 m long track section to maximum 20 m total length	Option
Cable chain in custom lengths on request	Option
Rotating module	Option
Oscillation type	Linear
Weld path	Straight, triangle, trapezoid, square
Oscillation width	0-11,4 cm (0-4 31/64")
Oscillation speed	0,1-2 m/min (4-79 inch/min)
Oscillation dwell time at center and on ends	0-5 s
Maximum oscillator pulling force	50 N
Weight (incl. 4 m standard track length)	484 kg

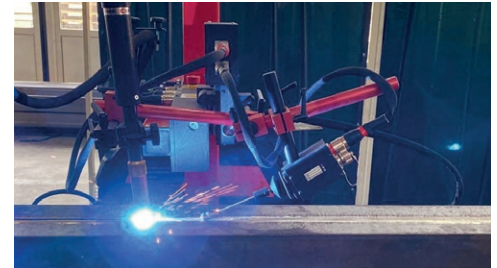

WA Compact Oscillation Paths

	Triangle. The machine travels only during oscillation. During oscillation dwell time, the machine stops to fill the crater.
	Trapezoid. The machine travels at all times, also during oscillation dwell time.
	Square. The machine travels only during oscillation dwell time in left and right position. During oscillation, the machine stops. During oscillation dwell time in center position the machine fills the crater.

Standard shipping set:

- Gantry welding system
- 4 m long track (total length up to 20 m on request)
- Arc ignition cable
- Remote control pendant
- Set of 4 signal cables
- Vertical slide
- Tracking sensor
- Fork tracking tip
- Torch holder and rod
- Long oscillator holder
- Rod clamp (2 pcs)
- Clamping block (2 pcs)
- 2 mm hex wrench
- 1.5 mm hex wrench
- Operator's manual

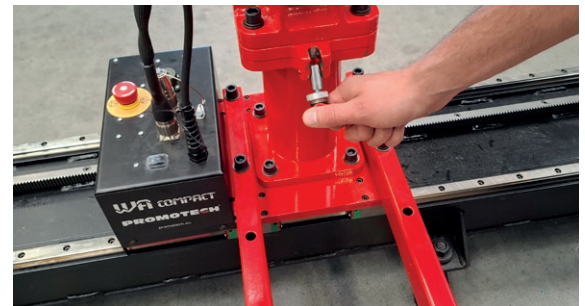
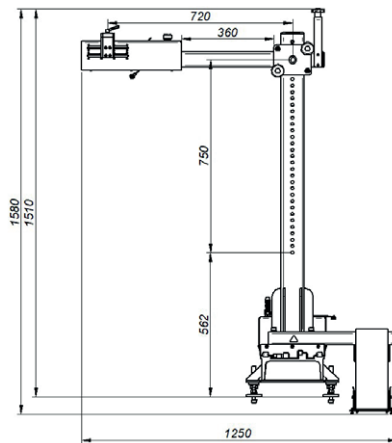

The optional rotating module enables the working arm to be repositioned depending on whether the welded part is on the right or left side of the track, or along the track axis, in order to deliver or collect the workpiece.

Optional accessories:

- ZSP-0814-12-00-00-0
Arm rotation assembly

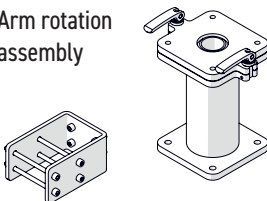

- ZSP-0814-14-00-00-0
Linear oscillator bracket

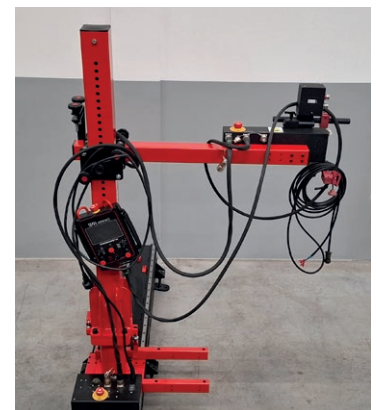
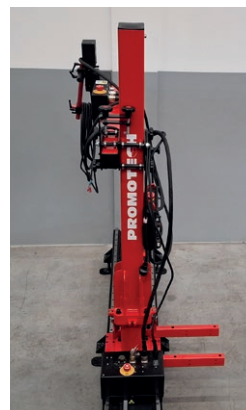

PPCM 650 | PIPE PROFILE CUTTING MACHINE

The CNC controlled Pipe Profile Cutting Machine allows 3D cutting/beveling using oxy-fuel or plasma.

Advanced design and top quality components enable fast and efficient cutting with top quality results.

Integrated library of macros allows for parametric definition of typical pipe joints and fast shape programming directly from machines' control panel or offline via technologist laptop, just after a short a couple of hours training.

Pipe joints can be prepared remotely in the office to keep machine operating, increasing process efficiency and reducing downtime.

Heavy duty design allows to extend warranty for 24 months, more available upon request!

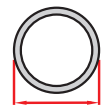

Pipe OD
50 to 650 mm (2-26")

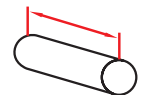

Max. pipe length
6 or 12 m



Pipe weight
up to 3 000 kg

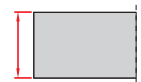

Wall thickness:
3 - 50 mm

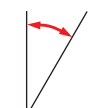

Max. cutting angle:
45 degree



3D Oxy-fuel bevel
Acetylene / Propane
 $\pm 45^\circ$



3D Plasma bevel
 $\pm 45^\circ$

Important features:

- User friendly software including library of macros for most typical cutting shapes
- Automatic compensation of cutting speed depending on the material thickness, torch angle and cutting direction for the best cutting quality
- Heavy duty rigid construction
- Well proven in most demanding environments
- Easy access to gas valves / flash back arrestors / cutting torch
- Fume extraction system thru spindle



CAD/CAM file transfer thru
Lantek Flex 3D Tubes
(option)

Options available upon customers' requests

- I. Oxy-fuel cutting (Acetylene or Propane)
Alternative cutting method that is available on request.
- II. Plasma Bevel - YES



III. Fume extraction system

Fume extraction system integrated with PPCM 650 thru spindle ensure the Client with effective fumes removal.



PPCM 650 TECHNICAL SPECIFICATION	
Pipe OD diameter	50 - 650 mm (2-26")
Max. pipe length	6 or 12 m (19 or 39 ft.)
Pipe weight	up to 3 000 kg
Wall thickness	3 - 50 mm
Max. cutting angle	± 45 degree
Cutting method	Oxy-Acetylene (Option) Oxy-Propane (Option) Plasma (Option)
Ignition: Oxy-fuel / Plasma	Manual / Automatic
Pipe support	2 pcs for up to 6-meter long pipes 4 pcs for up to 12-meter long pipes Additional supports on request
Vertical oval compensation mechanism	Included
Airconditioning of control cabinet	Option
Menu language	English, German, Croatian, Finnish, French, Russian, Turkish Other languages on request
Fume extraction system	Option
Auto nesting of multiple parts	Option
Transfer of NC data from CAD: Tekla files, SAT, STEP, IFC, Excel etc. files thru LANTEK flex 3D	Option



PPCM 1500 | PIPE PROFILE CUTTING MACHINE

The CNC controlled Pipe Profile Cutting Machine allows 3D cutting/beveling using oxy-fuel or plasma.

Advanced design and top quality components enable fast and efficient cutting with top quality results.

Integrated library of macros allows for parametric definition of typical pipe joints and fast shape programming directly from machines' control panel or offline via technolist laptop, just after a short a couple of hours training.

Pipe joints can be prepared remotely in the office to keep machine operating, increasing process efficiency and reducing downtime.

Heavy duty design allows to extend warranty for 24 months, more available upon request!

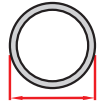

Pipe OD
100 to 1524 mm (4-60") for PPCM 1500

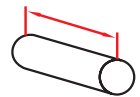

Max. pipe length
6 or 12 m



Pipe weight
up to 10 000 kg



Wall thickness:
3 - 50 mm

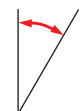

Max. cutting angle:
45 degree



3D Oxy-fuel bevel
Acetylene / Propane
 $\pm 45^\circ$



3D Plasma bevel
 $\pm 45^\circ$



CAD/CAM file transfer thru
Lantek Flex 3D Tubes
(option)

Important features:

- User friendly software including library of macros for most typical cutting shapes
- Automatic compensation of cutting speed depending on the material thickness, torch angle and cutting direction for the best cutting quality
- Heavy duty rigid construction
- Well proven in most demanding environments
- Easy access to gas valves
- Fume exhaust system thru spindle (option)

PPCM 1500 TECHNICAL SPECIFICATION

Pipe OD diameter	100 - 1524 mm (4-60")
Max. pipe length	6 or 12 m (19 or 39 ft.)
Pipe weight	up to 10 000 kg
Wall thickness	3 - 50 mm
Max. cutting angle	± 45 degree ± 70 degree (option for oxy-fuel)
Cutting method	Oxy-Acetylene (Option) Oxy-Propane (Option) Plasma (Option)
Ignition: Oxy-fuel / Plasma	Manual / Automatic
Pipe support	2 pcs for up to 6-meter long pipes 4 pcs for up to 12-meter long pipes Additional supports on request
Vertical oval compensation mechanism	Included
Airconditioning of control cabinet	Option
Menu language	English, German, Croatian, Finnish, French, Russian, Turkish Other languages on request
Auto nesting of multiple parts	Option
Transfer of NC data from CAD: Tekla files, SAT, STEP, IFC, Excel etc. files thru LANTEK flex 3D	Option
Fume extraction system	Option
Pipe marking system	Option

Options available upon customers' requests

I. Oxy-fuel cutting (Acetylene or Propane)

Alternative cutting method that is available on request.

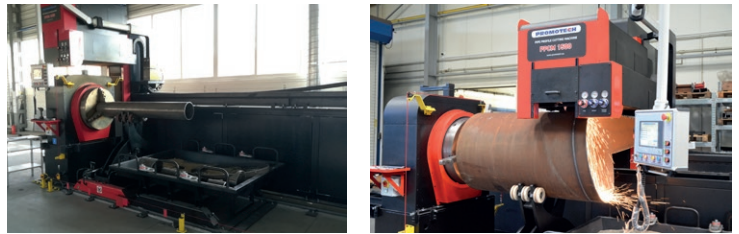

II. Plasma Cutting

We can integrate plasma source preferred by customer.



III. Cutting angle up to 70° for oxy-fuel cutting

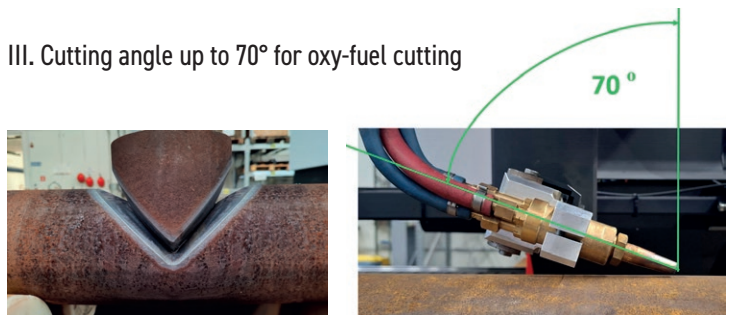

IV. Fume extraction system

Fume extraction system with electric adjustment of dirty air level, combined with PPCM 1500 spindle provides customer with effective fume removal.



V. Pipe marking system

For providing information about:

- part numbers
- designations
- cutting lines
- grinding lines
- etc.

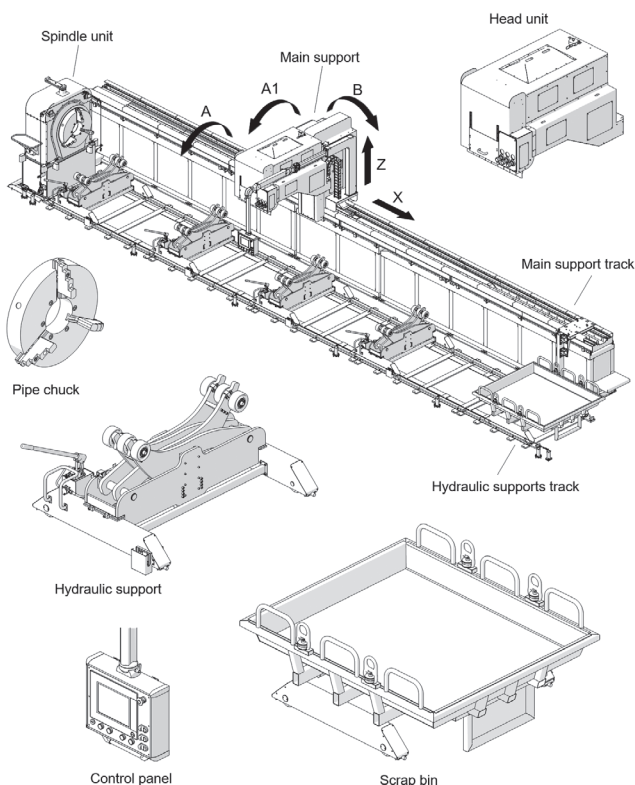

Machines' software for PPCM 650 and PPCM 1500

I. PPCM 650/1500 software includes a wide scope of standard macros.

The macros present the typical cutting shapes and are easily programmable thanks to intuitive menu with necessary pipe parameters.

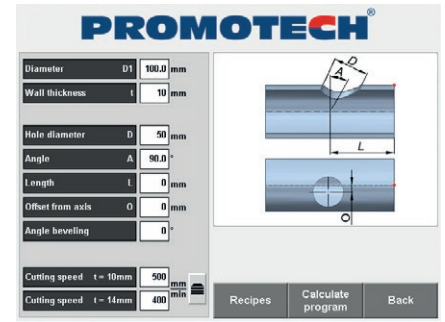

Typical cutting shapes:

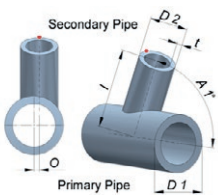

Pipe - pipe

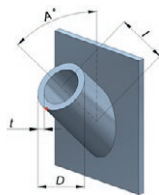

Pipe - plane

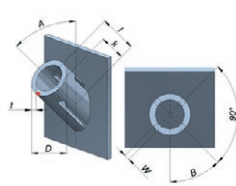

Pipe-plane with holes for fins

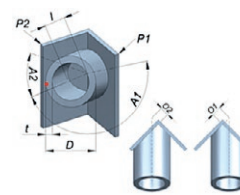

Pipe - planes

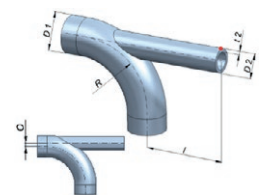

Pipe - elbow

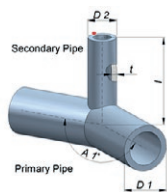

Pipe - joint

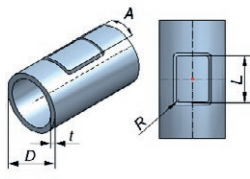

Rectangular pad

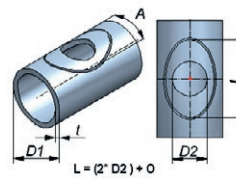

Reinforcement pad

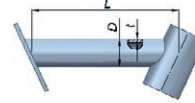

Compound cut

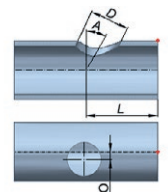

Round hole with bevel

Promotech can expand the macro library upon customer's request.

II. PPCM SIM PC / Off-line programming

Thanks to PPCM standard macros library you can work remotely on your projects.

Main features of PPCM SIM PC:

- all the macros from the PPCM library are also available on the PC
- time efficiency - when the PPCM machine is used for cutting, next project can be prepared on the PC in the meantime
- easy transfer between PC and PPCM machine using USB stick
- stand-alone application
- simple and user-friendly software

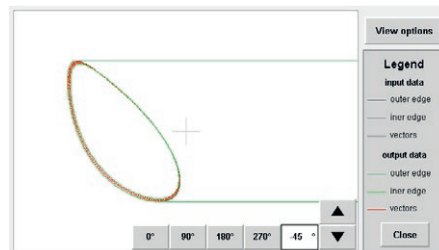
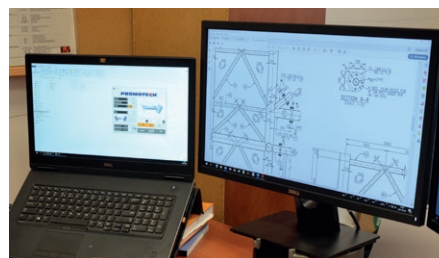

On-line service support



Built-in network router enables remote access to machine interface (VNC Network)



Cable connection or WiFi (option)



Compatible with mobile and desktop devices



On-request software updates and machine diagnostics

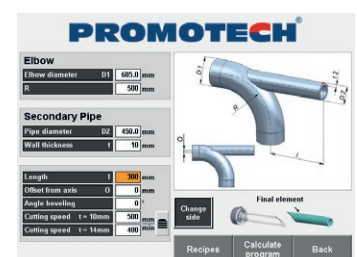



Lantek Flex 3D Tubes software for CAD/CAM file transfer (option)

This software being customized for PPCM enables a simple way of generating the CNC code necessary to cut complex pipe intersection shapes. Lantek Flex 3D Tubes software is a perfect tool to import CAD geometry, design tubes using a set of standard shapes, or construct them from 2D outlines and generate them with any type of contour projected through the tube.

Main benefits of optional Lantek Flex3d Tubes software

I. Import of CAD geometry from external software and acceptance of various file types including Tekla, SAT, STEP, IFC...

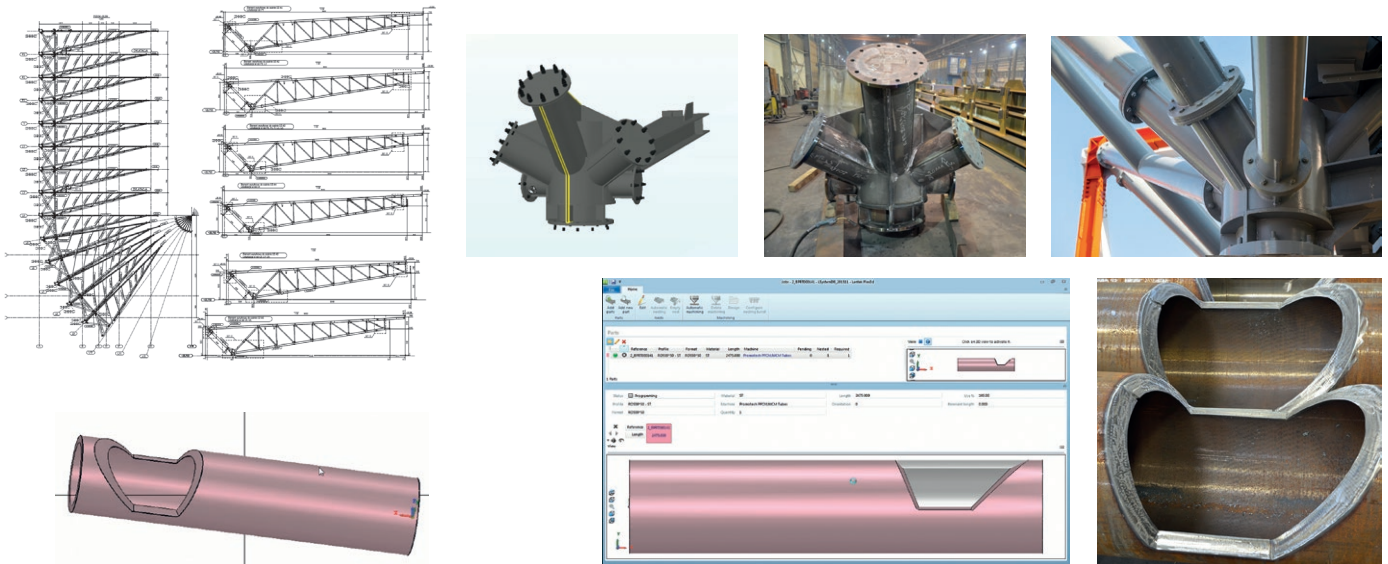

II. Designing of tubes and joints using a set of standard shapes or construction them from 2D outlines

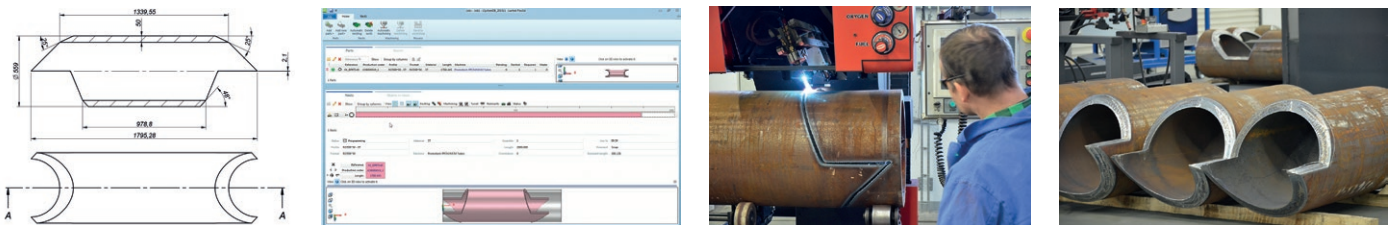

III. Visualization of joints and torch path adjustment to optimize weld preparation

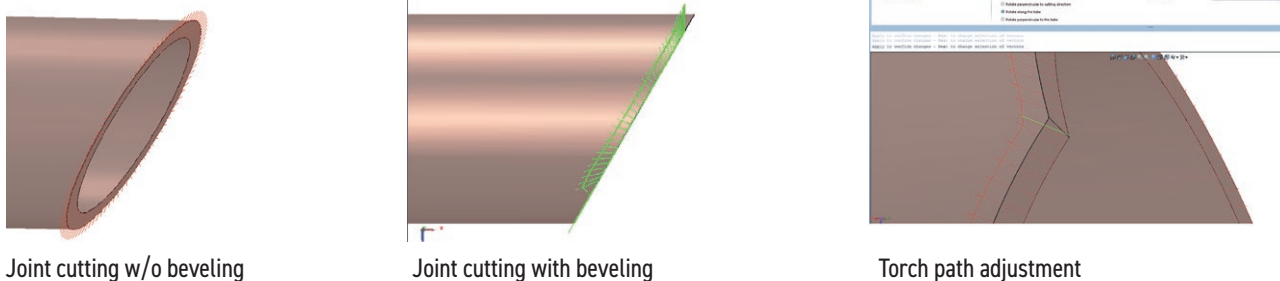

Joint cutting w/o beveling

Joint cutting with beveling

Torch path adjustment

IV. Auto Nesting of multiple parts

Lantek automatic nesting system determines the most efficient position of elements to be cut from pipes, thus minimizing waste of material as well as facilitating managing the warehouse of pipes.

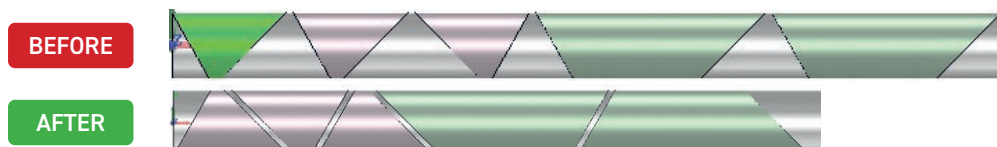

MCM MINI MCM 1000

5-AXIS TRUE PORTABLE CNC 3D CUTTING/BEVELING TO OFFSHORE TP'S AND XXL SIZE MONOPILES

Promotech MCM machines are a true portable CNC cutting and welding cartesian robots already proven with several Customers in Wind Business, including multiple successful installations!

Promotech's MCM supports Offshore projects with regards to cutting/beveling different openings in the TP's and Monopiles, XXL Monopiles.

MCM machines as standard are available in the configuration:

- MCM 3D oxy-cutting / beveling, for single or double sided bevel

Options:

- MCM 3D SAW ACDC welding (recommended)
- MIG-MAG / FCAW-G / MCAW (available upon Customer request only)

MCM main advantages:

- No CNC programming required
- Fast and easy positioning
- On-line service connection
- One-man operation
- 24 months extended warranty available

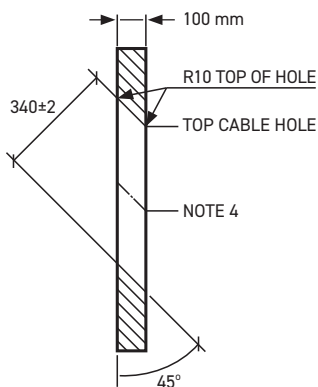

2D drawing, plate thickness approx. #100 mm.



Final result



Overall view of XL monopile



Overall view of XXL monopile

Typical MCM Offshore application



MCM machines are available with an on-line connection software (on demand)



Built-in network router enables remote access to machine interface (VNC Network)



WiFi and cable connections



Compatible with mobile and desktop devices



On-request software updates and machine diagnostics

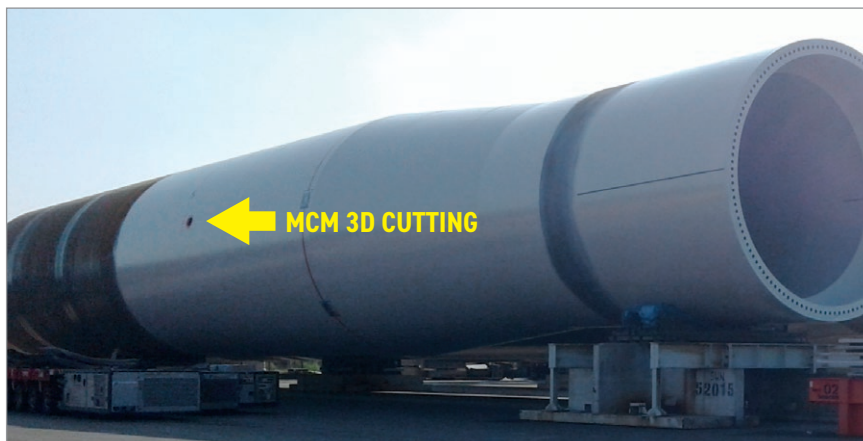

Overall view of XL monopile

■ **MCM 4000S, MCM 4000XW MCM 4000TW MCM 4500**

**5-AXIS TRUE PORTABLE CNC 3D CUTTING/BEVELING
AND WELDING CARTESIAN ROBOTS
RECOMMENDED TO ONSHORE AND OFFSHORE WIND
TOWERS MANUFACTURERS!**

MCM are true portable CNC scanning, cutting, beveling and welding robots that eliminates the biggest bottleneck in the steel wind towers production On&Offshore!

MCM 3D Oxy-fuel CNC 3D cutting&beveling head ensure top quality welding preparation each time!

MCM SAW ACDC welding head increases deposition rate up to 14 kg/hour at 100% boost productivity and significantly reduce the largest component of welding costs – labor and overhead!



■ **MCM robots are available in the configuration:**

- 4000 S / 4500 onshore / 4000 offshore / 5000+ offshore
- 3D Oxy-fuel cutting&beveling kit for single V or double sided bevel
- 3D SAW ACDC / Unbalance AC Single Wire

■ **Features & Benefits:**

- Short setup time and easy handling
- Each workpiece (e.g. doorframe) is scanned to automatically obtain individual shape, CNC cutting/beveling and CNC welding path
- Top quality weld preps / aperture root gap 1-3 mm
- Welding defect rate less 1% / no grinding
- One-man operation
- Excellent Return On Investment (ROI)!
- Multiple successful installations to the Clients in the Wind Business!
- Production support by means of WPQR / WPS development
- Production support by means of well experienced PROMOTECH expert operators
- 100% design and made in the EU (Poland)
- 24 months extended warranty available



ON&OFFSHORE WIND TOWERS APPLICATION: DOOR / VENTILLATION FRAMES

Weld prep: 3D Oxy-fuel double bevel

Welding: 3D SAW ACDC 4.00 mm single wire

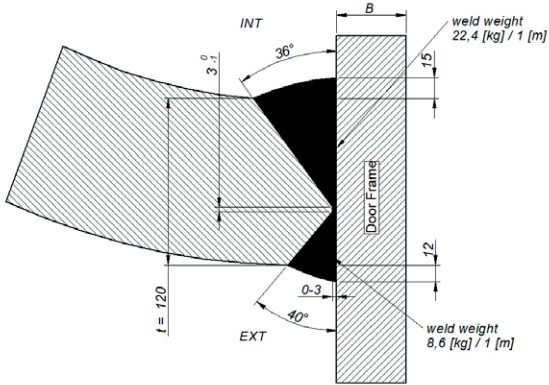

MCM SAW welding joint design: double bevel 2/3 inside; 1/3 outside

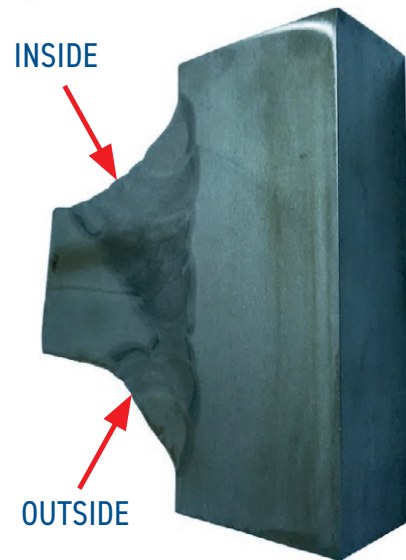

3D CNC Oxy-fuel cutting&beveling inside tower section / aperture door assembly & fit up



One-man operation!

3D CNC SAW ACDC welding inside&outside of tower section!



One-man operation!

True portable MCM Cartesian robot
for fast and easy handling Inside&Outside tower section!



Standard technical data to MCM Onshore and Offshore applications

MODEL/PARAMETER		MCM Mini	MCM 1000	MCM 4000 S	MCM 4000 XW	MCM 4000 TW	MCM 4500
Overall dimensions	L [mm]	4340	4340	6240	6240	6260	6860
	W [mm]	2460	2460	2850	3000	3350	3050
	H [mm]	2070	2070	2150	2270	2150	2190
Range of straight cut hole		1000 x 2200		1600 x 4400	1700 x 4400	2100 x 4400	1800 x 4900
Range of bevelled hole				1300 x 4100	1400 x 4100	1800 x 4100	1500 x 4600
Range of welded hole				1200 x 4000	1300 x 4000	1700 x 4000	1450 x 4500
Minimum inner diameter of the section [ϕ D1 mm]		3000	3500	3900	4000	4900	4300
Minimum distance of the frame from the flange [mm]		N/A	N/A	600	600	600	600
Weight of the machine without equipment [kg]		720	720	950	980	1070	1050
Maximum process speed (single axis) [mm/min]		2000					
Maximum bevel angle [°]		45					
Maximum welding angle [°]		30					
Power [W]		1500					
Voltage [V, Hz]		3~ 380-480VAC + PE (\pm 10%) 50/60Hz					
Number of numerically controlled axes		5					

* With large thicknesses (above 80mm), the working ranges are reduced - this should be considered individually

On-line service support connection available! (on demand)



Built-in network router enables remote access to machine interface (VNC Network)



WiFi and cable connections



Compatible with mobile and desktop devices



On-request software updates and machine diagnostics



Promotech service team support on site (scheduled preventive maintenance)

SWSO | CIRCULAR WELDING SUPPORT SYSTEM

The SWSO – circular welding support system is capable of circumferential welding of pipe elements, flanges and fasteners such as elbows, tees etc.

The system is available in two essential configurations for standalone operation (3 voltage variants) and for use with the PROMOTECH Premium Positioners.

Depending on the task at hand, the SWSO can be used in a basic or more advanced configuration by choosing from the following components:

- Torch stand
- Linear oscillator
- Power supply unit
- Motorized vertical slide
- Seam tracking attachment
- Remote control pendant
- Remote control cables

TIG
compatible



Features and benefits:

- Ergonomic remote control pendant with LCD display and simple, easy-to-find knobs allows intuitive and fast adjustment of welding parameters without lifting the operator's welding hood
- Seam tracking attachment along with motorized vertical slide ensure active compensation of torch position vertically and horizontally with and without oscillation for high-quality welds
- Provides a variety of weld paths with straight, triangular and trapezoidal oscillation patterns
- **The full potential can be reached when integrated with the PROMOTECH premium positioners**

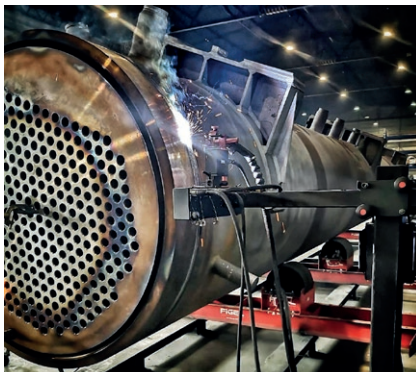

The system is available in two essential configurations for standalone operation (3 voltage variants) and for use with the PROMOTECH Premium Positioner.

SYS-0720-10-20-00-0	SWSO for standalone operation, plug EU	SWSO for standalone operation			SWSO for use with PROMOTECH Premium Positioners
		EU	D	US	
OSC-0720-01-00-00-0	Linear oscillator	•	•	•	•
CZJ-0654-05-00-00-0	Seam tracking attachment	•	•	•	•
OSK-0654-04-00-00-0	Motorized vertical slide	•	•	•	•
KBL-0466-17-00-00-0	Start-Stop arc ignition cable 6,5 m	•	•	•	•
PWD-0736-30-00-00-0	Transmission cable 3 m	•	•	•	•
ZSL-0720-03-00-05-0 (230V, EU) ZSL-0720-03-00-04-0 (230 V, D) ZSL-0720-03-00-01-0 (115 V, US)	Power supply unit	•	•	•	N/A
PNL-0736-23-00-00-0	Remote control pendant for SWSO	•	•	•	N/A

Linear Oscillator

Oscillation width	115 mm
Oscillation speed	10-200 cm/min.
Oscillation delay time	0-5 s
Vertical slide altitude range	50 mm

Linear Oscillation Paths



Remote Control Pendant

Depending on the SWSO configuration, the remote control pendant allows for setting and adjustment of the following parameters:

- Oscillation offset
- Oscillation dwell time in left position
- Oscillation dwell time in center position
- Oscillation dwell time in right position
- Oscillation width
- Oscillation speed
- Torch height
- Tracking sensor tilt in Y and Z axes



■ The SWSO system can be equipped with either a standard or and XL torch stand, depending on customer needs.

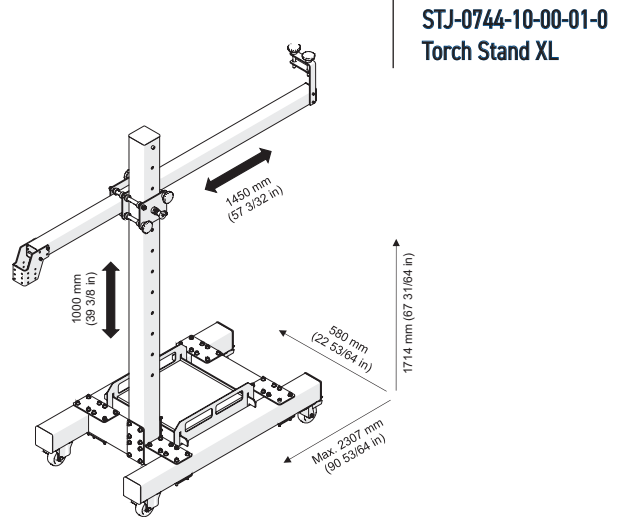
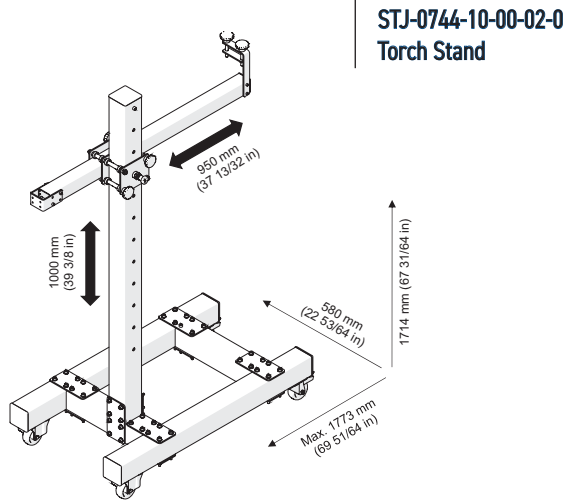

■ SWSO - Circular Welding Support System for standalone operation

STJ-0744-10-00-02-0
Torch Stand

STJ-0744-10-00-01-0
Torch Stand XL

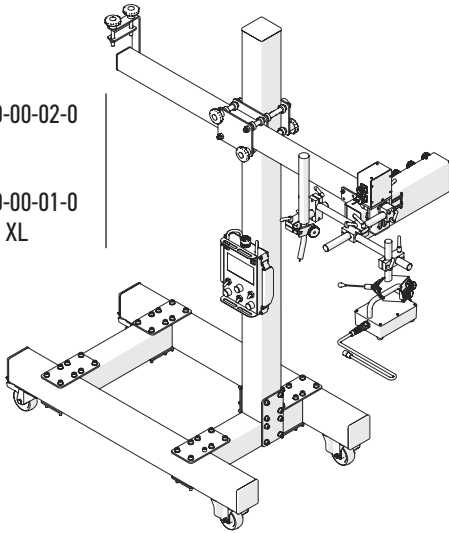

SYS-0720-10-20-00-0
SWSO for standalone operation, EU

SYS-0720-10-20-01-0
SWSO for standalone operation, D

SYS-0720-10-10-00-0
SWSO for standalone operation, US

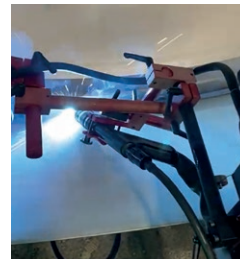

■ Optional accessories



- Cross slide assembly (option)
35 mm x 35 mm (left & right, up & down)
- ZSP-0466-14-00-00-0



- Sensor rod with tip I with rod for seam tracking
- ADT-0506-40-00-00-0



- Sensor rod with tip II with rod for seam tracking
- ADT-0506-41-00-00-0



- Sensor rod with tip IV with rod for seam tracking
- ADT-0506-43-00-00-0



- Guiding rod for seam tracking attachment
- PRT-0550-05-00-00-0



- Sensor rod with a ball tip for seam tracking attachment
- ELM-0523-07-01-14-0



- Sensor rod with a fork tip for seam tracking attachment
- PRT-0523-07-01-16-0



- Sensor rod for tips for seam tracking attachment
- WSP-0523-07-01-13-0



- KBL-0466-17-00-04-0
- Start-Stop arc ignition cable 13 m



- PWD-0736-30-00-00-0
- Transmission cable 3 m



- PWD-0736-30-00-01-0
- Transmission cable 5 m



- PWD-0736-30-00-02-0
- Transmission cable 10 m

PRO-WP 300P PRO-WP 750P

PREMIUM WELDING POSITIONERS

Premium Positioners:

- user-friendly control panel to set and monitor process parameters
- speed stabilization within full speed range from 0,12 rpm up to 2,4 rpm
- continuous speed adjustment
- setting and reading of key welding parameters in cm (inches) and cm/min or inches/min
- arc ignition control with pre and post crater fill adjustment
- left and right rotation
- heavy-duty construction
- recommended cooperation with optional Mini C&B System in order to configure an advanced modular welding station



CONTINUOUS WELDING	INTERMITTENT WELDING	AUTOMATIC INTERMITTENT WELDING	OVERLAP WELDING	HARDFACING
--------------------	----------------------	--------------------------------	-----------------	------------

A portable control panel allows the operator to easily enter data and conveniently monitor various aspects of the welding process.

	Input of workpiece dimension information into the system
MODE	Selection of the welding procedure and precise setting of its parameters (e.g. continuous, intermittent, number of welds, back welding, overlap, crater fill etc.)
	Selection of automatic tracing in the y-axis, z-axis or simultaneously in the y-axis and z-axis

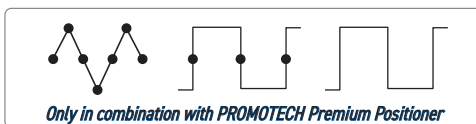

Positioner technical specification	Premium 300	Premium 750
Speed range min/max	0,12 - 2,4 rpm	0,035 - 1,4 rpm
Max load capacity	300 kg	750 kg
Mass center offset at a 90° tilt	up to 100mm	up to 150 mm
Faceplate diameter	630 mm	920 mm
Tilt angle range	0-90°	0-135°
Tilt angle adjustment	manually	motorized
Hollow-shaft inside diameter	28 mm	28 mm
Max welding current transfer	400 A	550-600A
Voltage	220-240 V, 50-60 Hz 100-120 V, 50-60 Hz	3x400V 50/60 Hz
Product code	PZY-0730-10-20-00-0	PZY-0736-10-40-00-0

SWSO - Circular Welding Support System for use with PROMOTECH Premium Positioners

STJ-0744-10-00-02-0
Torch Stand

STJ-0744-10-00-01-0
Torch Stand XL

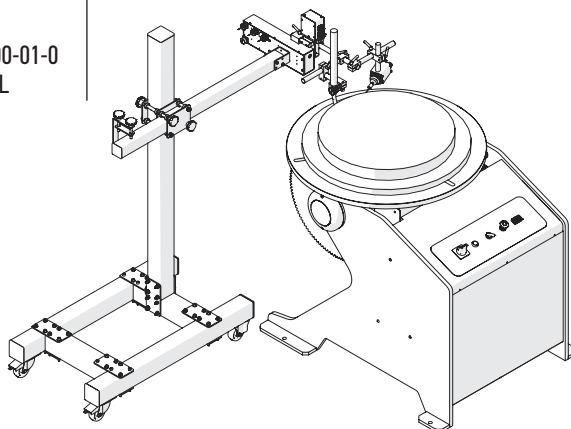

SYS-0720-10-00-01-0
SWSO for use with PROMOTECH Premium Positioners

PZY-0730-10-20-00-0
Positioner Premium 300

PZY-0736-10-40-00-0
Positioner Premium 750



PRO-WP 150 PRO-WP 300

STANDARD WELDING POSITIONERS

The welding positioners enable round or tubular pieces of metal to be rotated easily, provide better weld seam accessibility, can help produce high quality welds and increase deposition rates.

Frequency inverter ensures continuous speed adjustment and speed stabilization at the set value. They reduce time and effort for the welders, who can focus on their job with no need to constantly move around their workspace in order to get the best position.

The compact design takes up minimal floor space and tilting up to 90 degrees improves ergonomics of the workspace.

Selection of various auxiliary accessories make it possible to create an advanced modular welding station and customize it depending on required welding or cutting applications to maximize production efficiency.

Primary features and benefits:

- Left or right rotation
- Continuous speed adjustment
- Speed stabilization within full speed range from 0,12 rpm up to 2,4 rpm
- Start/Stop (both controller and foot pedal)
- Arc ignition
- Remote control
- Foot pedal for hands-free operation
- Heavy duty construction
- Lots of auxiliary accessories enable building a modular welding station tailored for various welding and cutting applications



TECHNICAL SPECIFICATION	PRO-WP 150	PRO-WP 300
Voltage	1~ 220-240 V, 50-60 Hz 1~ 100-120 V, 50-60 Hz	1~ 220-240 V, 50-60 Hz 1~ 100-120 V, 50-60 Hz
Power	0,25 kW	0,25 kW
Speed range min/max	0,12 - 2,4 rpm	0,12 - 2,4 rpm
Max load capacity	150 kg (331 lbs)	300 kg (661 lbs)
Mass center offset from the table at a 90° tilt	up to 100 mm	up to 100 mm
Faceplate diameter	450 mm (17.7")	630 mm (24.8")
Hollow-shaft inside diameter	28 mm (1.1")	28 mm (1.1")
Tilting range with continuous angle adjustment	0-90°	0-90°
Tilting	manual	manual
Max. welding current transfer	400 A	400 A
Weight	115 kg (254 lbs)	150 kg (330 lbs)
Product code:	PZY-0681-10-10-00-0	PZY-0682-10-10-00-0



The arc ignition allows the welding torch to be switched on and off remotely.

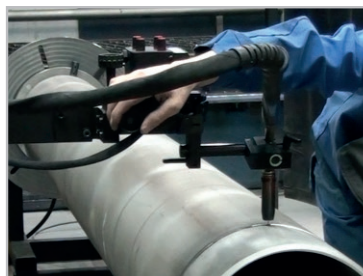

■ **Optional accessories for various welding and cutting applications:**

- Lathe self-centering chuck D250



External clamping diameter: Φ 90-250 mm
 Internal clamping diameter: Φ 6-110 mm,
 Φ 80-250 mm

UCW-0681-18-00-00-0

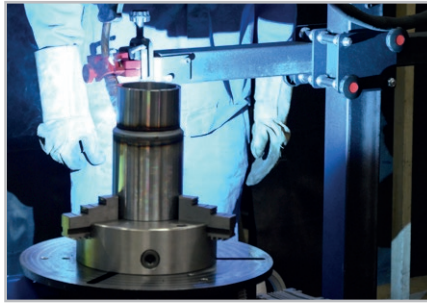

- Lathe self-centering chuck D400



External clamping diameter: Φ 120-400 mm
 Internal clamping diameter: Φ 15-210 mm,
 Φ 120-400 mm

UCW-0681-17-00-00-0

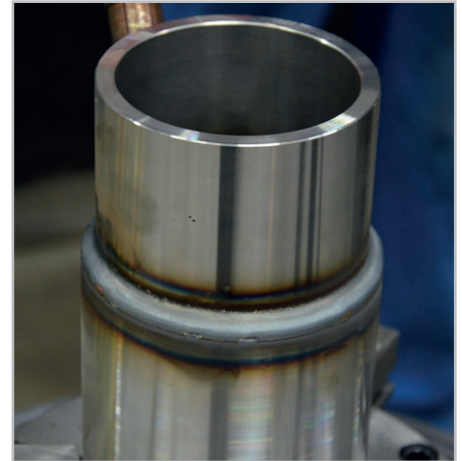
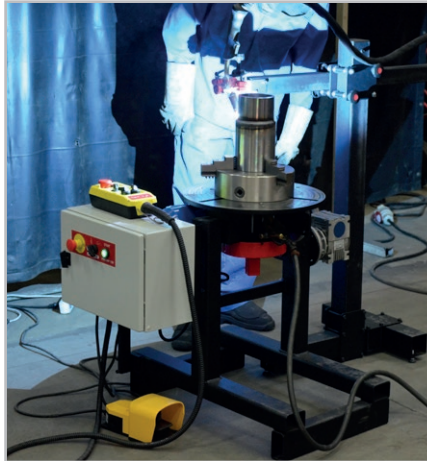

- Keyless self-centering chuck DD300



External clamping diameter: Φ 170 - 280 mm
 Internal clamping diameter: Φ 80 - 190 mm
 UCW-0681-19-00-00-0

- Keyless self-centering chuck DD400



External clamping diameter: Φ 250 - 380 mm
 Internal clamping diameter: Φ 120 - 250 mm
 UCW-0681-20-00-00-0

- Torch Holder



To be fixed directly on positioner
 UCW-0681-14-00-00-0



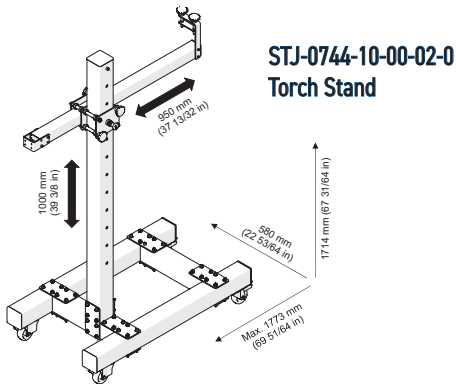

STJ-0744-10-00-02-0
Torch Stand

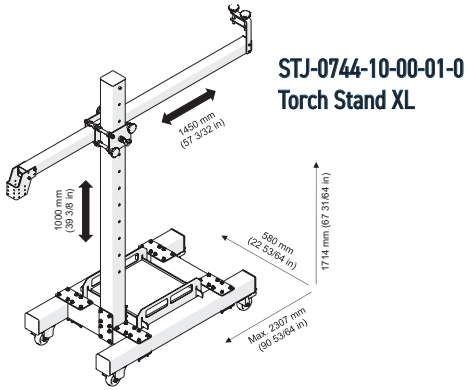

STJ-0744-10-00-01-0
Torch Stand XL

- Pendulum Oscillator OSC-8 PRO



Product code: OSC-0799-10-00-00-0

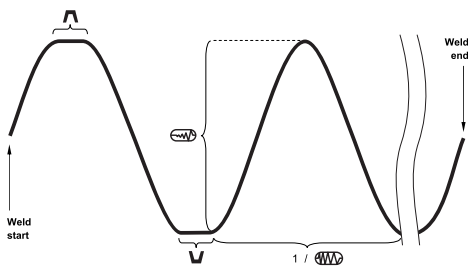

Parameter	Value	Description
	3-99%	Oscillation width
	0-99% (where 0%=5s, 99%=0.2s) 0.2-5 s	Oscillation speed
	0-5 s [step: 0.1]	Oscillation dwell time in right position
	0-5 s [step: 0.1]	Oscillation dwell time in left position



- Cross slide assembly (option)



35 mm x 35 mm (left & right, up & down)
ZSP-0466-14-00-00-0

- Roller support



Load capacity: 1000 kg (2200 lbs)
WSP-0681-16-00-00-0

- Power Supply

Product codes:
ZSL-0720-03-00-05-0 (230V)
ZSL-0720-03-00-04-0 (230 V, India type D)
ZSL-0720-03-00-03-0 (230 V, UK type G)
ZSL-0720-03-00-02-0 (230 V, Australia)
ZSL-0720-03-00-01-0 (115 V)

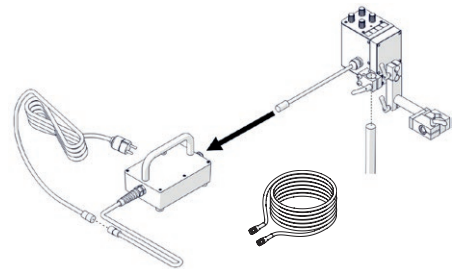

- PWD-0720-04-00-00-0
Cable connecting adapter
1 m for OSC-8 PRO



OSC-8 PRO TECHNICAL SPECIFICATION	
Voltage	14-24 V DC
Power	50 W
Torch type	MIG/MAG
Torch diameter	16-22 mm (5/8"-55/64")
Oscillation type	Angular
Oscillation width at r=150 mm (5 29/32")	1-30 mm; 3/64"-1 3/16" (3-99%)
Oscillation speed at oscillation width of 10 mm (3/8") and zero dwell time on ends	12-300 cycles/min
Dwell time on ends	0-5 s
Maximum torque	8 N·m
Protection level	IP 20
Protection class	I
Required ambient temperature	0-50°C (32-122°F)
Weight	2.1 kg (4.6 lbs)

■ Clamping accessories for welding torches (to choose from)

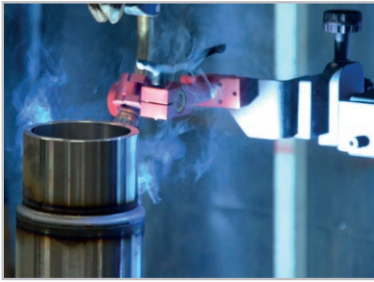

- Short rod torch holder with clamp 16-22 mm UCW-0754-07-00-00
- Long rod torch holder with clamp 16-22 mm UCW-0752-07-00-00
- Short low rod torch holder with clip 16-22 mm UCW-0476-06-00-00
- Short rod torch holder with clip 16-22 mm UCW-0476-27-00-00
- Long rod torch holder with clip 16-22 mm UCW-0466-22-00-00

■ Clamping accessories for cutting torches (to choose from)



- Standard torch holder incl. clamp 28-35 mm and angle adjustment UCW-0475-28-00-00
- Precise torch holder incl. clamp 28-35 mm with angle and height adjustment UCW-0753-08-00-00
- 150 mm long rod SLP-0233-13-02-00-1
- Standard machine torch holder for oxy-fuel cutting with vertical position setting and rough angle adjustment
Machine torch holder 30 mm (1-3/16") UCW-0475-61-00-00-0
Machine torch holder 35 mm (1-3/8") UCW-0475-29-00-00-1
- Precise machine torch holder for oxy-fuel cutting with vertical position setting and precise angle adjustment.
Precise machine torch holder 30 mm (1-3/16") with angle adjustment UCW-0753-22-00-00-0
Precise machine torch holder 35 mm (1-3/8") with angle adjustment UCW-0753-24-00-00-0

• Clamping set
Product code: ZST-0681-15-00-00

- Clamp 100mm x 32mm x 19mm (3 pcs)
- Clamp 150mm x 32mm x 22mm (3 pcs)
- Step block 28mm x 20mm - 38mm (4 pcs)
- Step block 35mm x 28mm - 64mm (4 pcs)
- Step block 98mm x 64mm - 152mm (4 pcs)
- Double end stud bolt 75mm x 30mm (4 pcs)
- Double end stud bolt 100mm x 30mm (4 pcs)
- Double end stud bolt 125mm x 30mm (4 pcs)
- Double end stud bolt 150mm x 30mm (4 pcs)
- Double end stud bolt 175mm x 30mm (4 pcs)
- Double end stud bolt 200mm x 30mm (4 pcs)
- Flanged nut M10 x 15mm (6 pcs)
- Extension nut M10 x 30mm long (4 pcs)
- T-slot nut 12mm x 18mm x 14mm (6 pcs)

JTS | AUTOMATIC JOINT TRACKING SYSTEM

The Joint Tracking System automatically guides the welding torch properly with respect to the weld joint in two axes.

It is suitable for GMAW, GTAW, FCAW and SAW applications and can be fitted to column and boom welding manipulators, gantry welding systems and other purpose-designed welding systems.

The electro-mechanical seam tracking system keeps maintaining the correct position of the welding torch relative to the welding groove set at the beginning.

Any changes in inclination of a tracking sensor tip generate electrical signal resulting in active compensation of torch position and its motion up to 200 mm in both axes of standard motorized cross slide system.

Movement range can be customized upon customer's request.

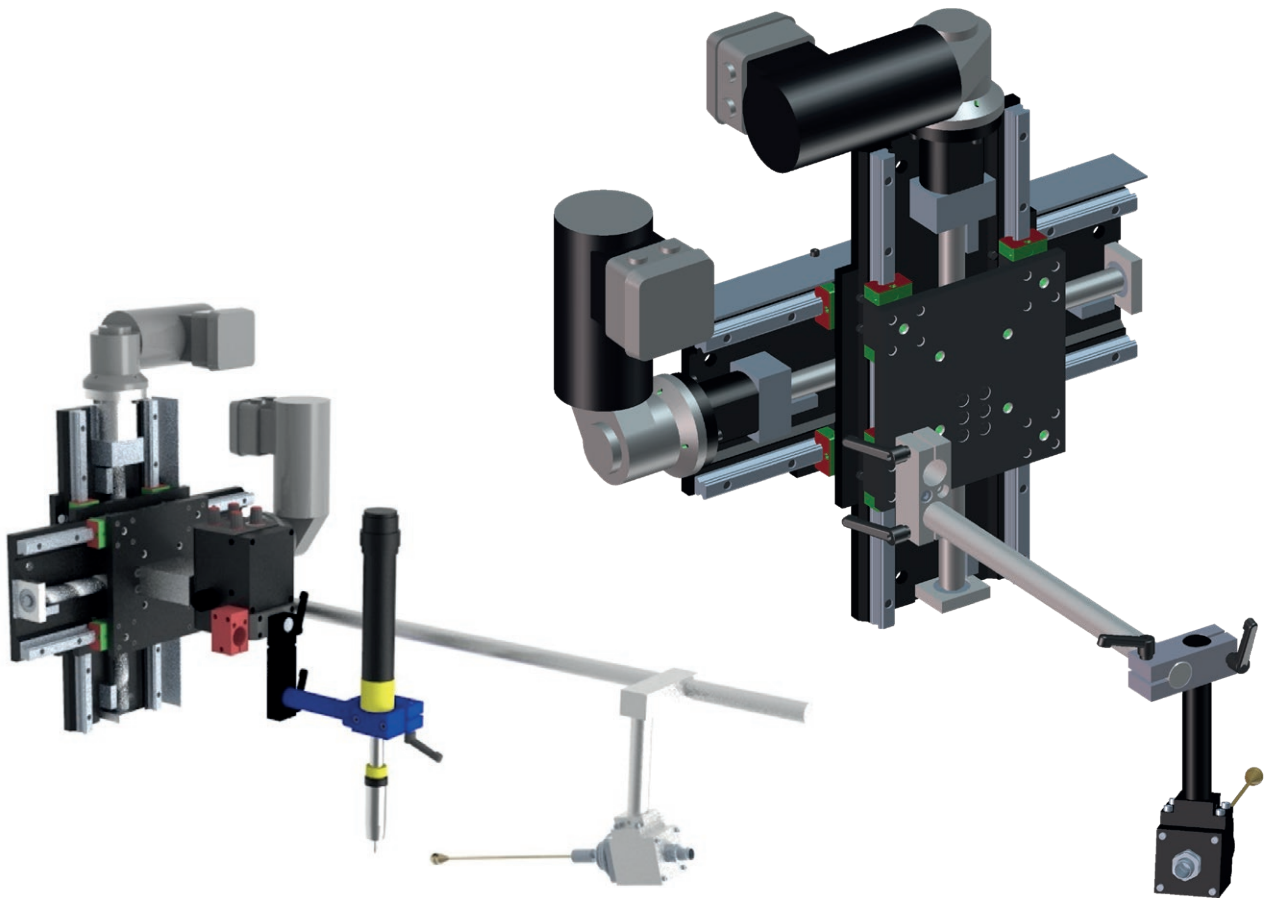

■ Features and benefits:

- JTS system is perfect for fillet and butt welding in tanks, vessels as well as construction beams
- Can be applied for both circumferential and longitudinal welding
- Electro-mechanical joint tracking system with high-precision linear guides ensures precise and smooth motion of 2 axes (up-down, right-left)
- Real-time compensation of head position relative to the welding groove
- Possibility to track only in one Z-axis (up-down) useful for butt welding
- Minimized welding defects and grinding
- Standard movement range of 200 x 200 mm to be customized upon customer's request
- User friendly control pendant
- Can be integrated with pendulum oscillator OSC-8 PRO (option)

TECHNICAL SPECIFICATION FOR JTS - JOINT TRACKING SYSTEM 200 X 200	
Voltage	230 V, 50/60 Hz + PE
Power	500 W
Cross slide vertical movement range (up-down axis)*	200 mm (7.9")
Cross slide horizontal movement range (right-left axis)*	200 mm (7.9")
Cross slide vertical movement speed (up-down axis)	360 mm/min (14.2 in/min)
Cross slide horizontal movement speed (right-left axis)	360 mm/min (14.2 in/min)
Required ambient temperature	5-40°C (41-104°F)
Weight	45 kg (100 lbs)
Integration with external safety devices	YES

* Movement range can be customized upon customer's request.

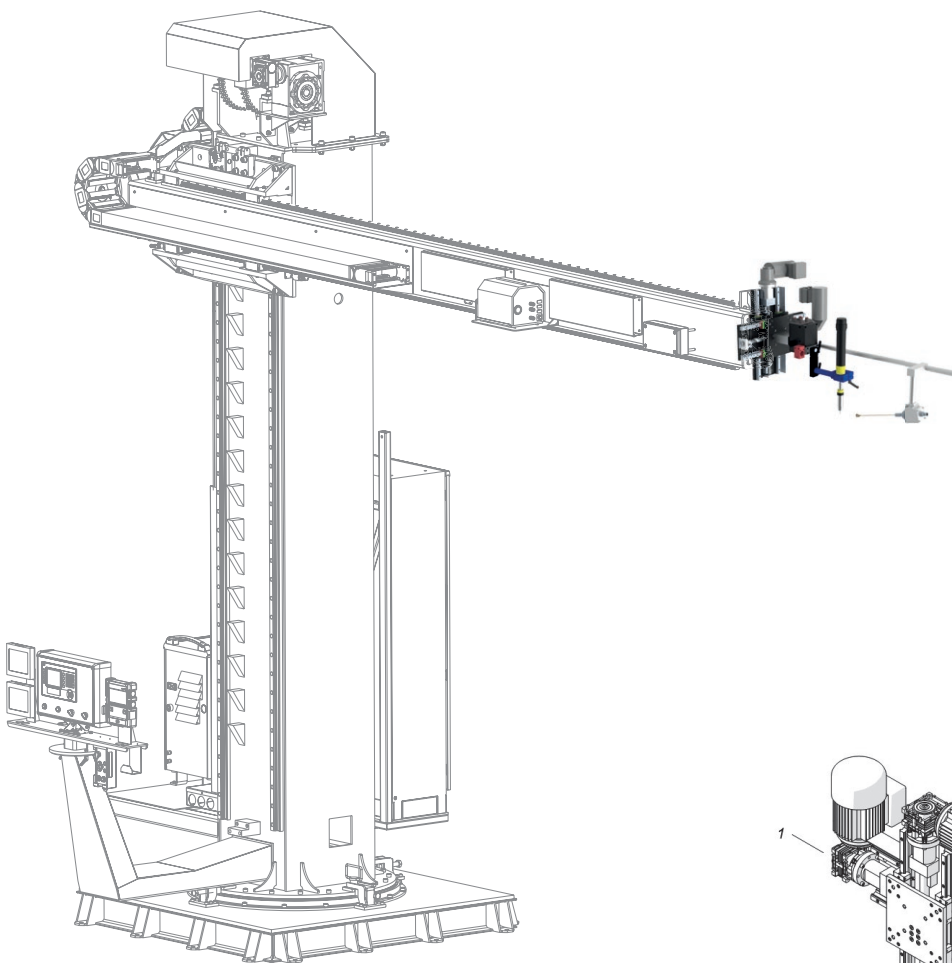
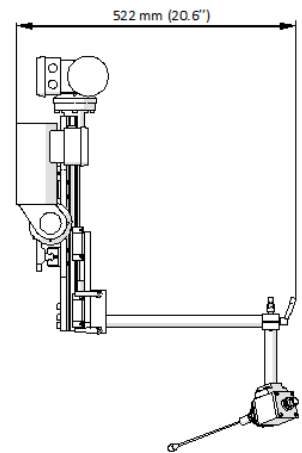
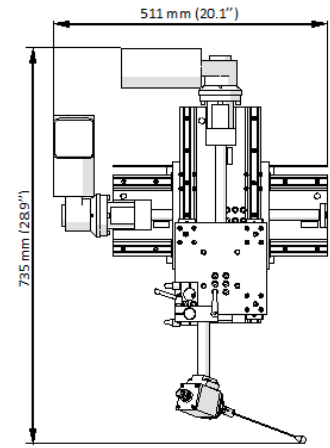

Standard shipping set:

1. cross slide - 1 pc
2. tracking sensor - 1 pc
3. sensor mounting set - 1 pc
4. control cabinet - 1 unit
5. sensor rod with a ball tip - 3 pcs
6. sensor rod with a bent tip - 2 pcs
7. sensor rod with a fork tip - 2 pcs
8. adapter - 3 pcs
9. control pendant - 1 pc

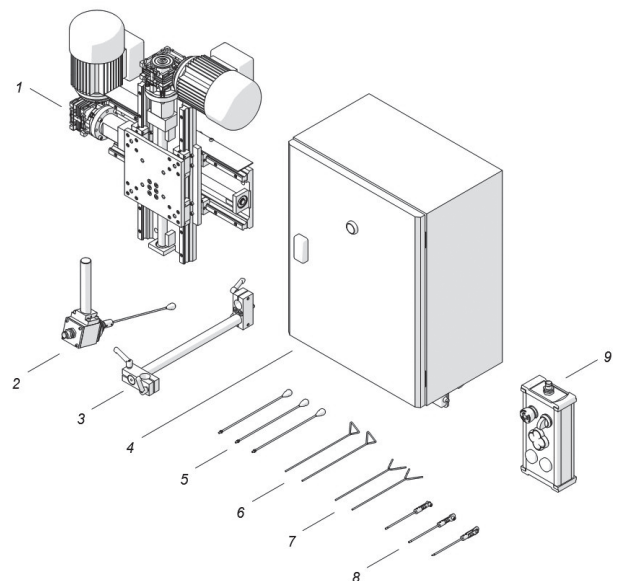

The JTS can be enriched with oscillator and visual system



WIRE FEEDER BOOMS

Highly useful devices that improve ergonomics and increase flexibility of welding stations.

Main features and benefits:

- extended workspace
- more freedom of movement over significantly larger area comparing to the traditional setup
- no wires on the floor
- no mess of tangled cables that in extreme cases can be outright dangerous
- more convenient welding of bigger and complex constructions
- simple and robust device
- can be easily mounted to the construction elements of the production halls with no need for any additional infrastructure
- permissible load: up to 50 kg



Three types to choose from:

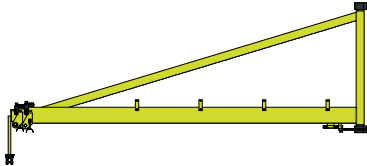

Wall mounted telescopic wire feeder boom

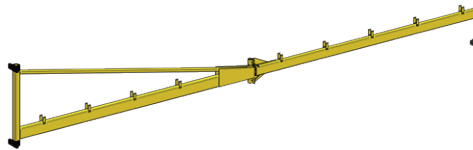

Wall mounted pivot wire feeder boom

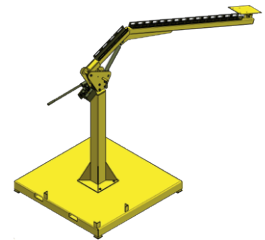

Hydraulic wire feeder boom

Wall mounted telescopic wire feeder boom

- can rotate up to 180° around the vertical axis
- two types of frames: either welded or bolted for self-assembly after shipping
- two adjustable ranges of movable arms: either up to ca 6000 mm or up to ca 8000 mm
- two types of holders: either R type or L type
- eight various models altogether



Adjustable reach of telescopic wire feeder booms

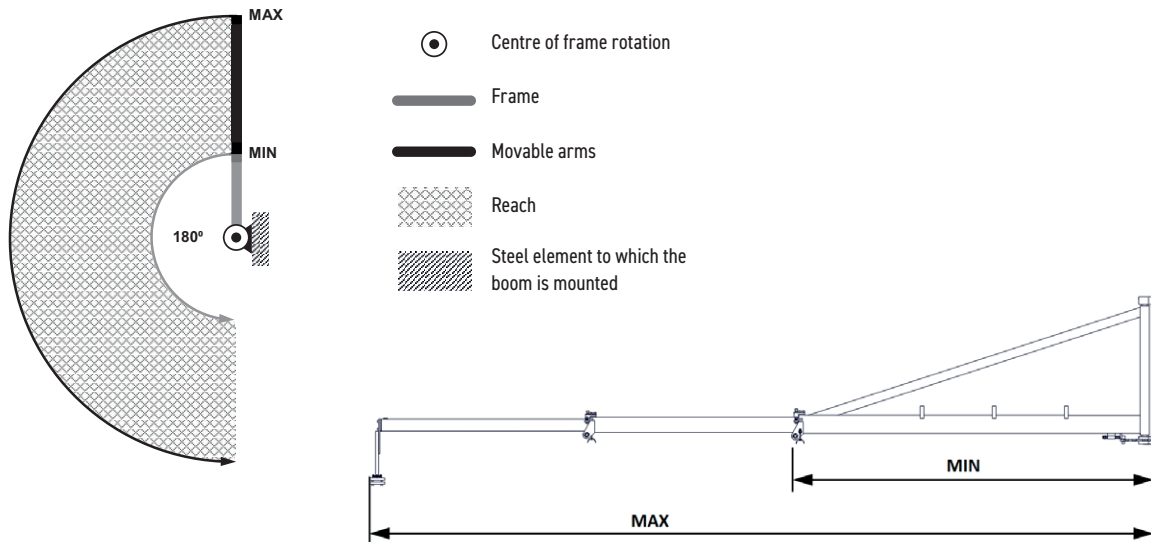

TELESCOPIC	Frame	Reach (Min - Max)	Rotation	Max. load	Weight	Holder type	Product code
TL6000 WL	Welded	2500-5980 mm	0-180°	50 kg	95 kg	L	WSG-0569-10-00-01-0
TL6000 WR	Welded	2550-6030 mm	0-180°	50 kg	95 kg	R	WSG-0569-10-00-02-0
TL8000 WL	Welded	3250-7710 mm	0-180°	50 kg	120 kg	L	WSG-0429-10-00-01-0
TL8000 WR	Welded	3310-7770 mm	0-180°	50 kg	120 kg	R	WSG-0429-10-00-02-0
TL6000 BL	Bolted	2540-5990 mm	0-180°	50 kg	107 kg	L	WSG-0767-10-00-00-0
TL6000 BR	Bolted	2590-6040 mm	0-180°	50 kg	107 kg	R	WSG-0767-10-00-01-0
TL8000 BL	Bolted	3320-7750 mm	0-180°	50 kg	130 kg	L	WSG-0732-10-00-00-0
TL8000 BR	Bolted	3370-7800 mm	0-180°	50 kg	130 kg	R	WSG-0732-10-00-01-0

Bolted frame versions

To optimize transport costs, PROMOTECH offers a new line of wire feeder booms (both pivot and telescopic) with a bolted frame that is disassembled for delivery and ready for self-assembly after shipping. Each bolted wire feeder boom is individually packaged in a wooden shipping box.

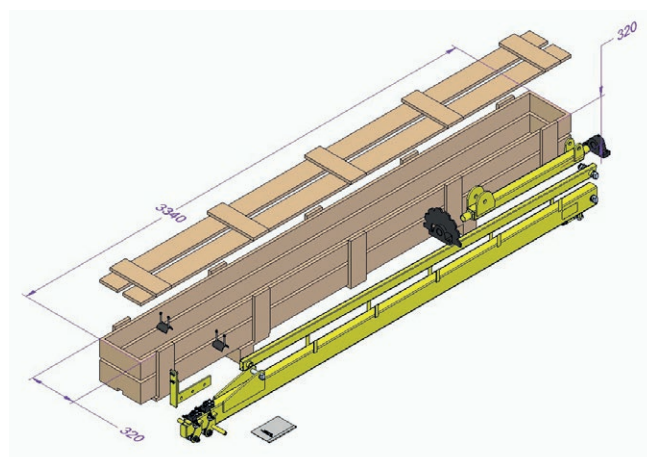
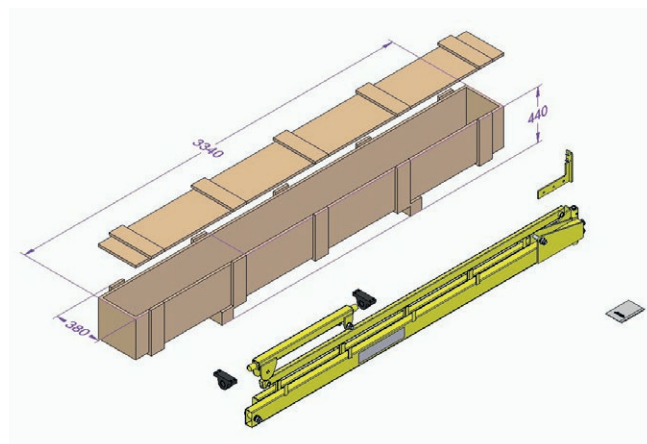

Wall mounted pivot wire feeder boom

- can rotate up to 180° around the vertical axis
- additionally the movable arm can be rotated up to 180° around the pivot
- two types of frames: either welded or bolted for self-assembly after shipping
- adjustable reach of movable arm: up to ca 6000 mm
- two types of holders: either R type or L type
- four various models altogether



Reach of pivot wire feeder booms

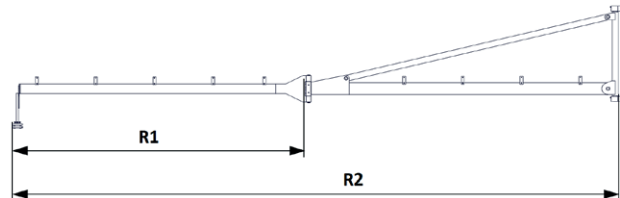
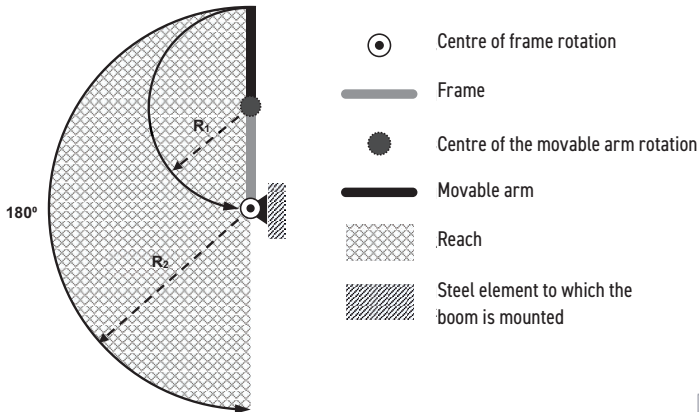

PIVOT	Frame	Reach (R1 - R2)	Rotation	Max. load	Weight	Holder type	Product code
WP6000 WL	Welded	2830-5940 mm	0-180°	50 kg	100 kg	L	WSG-0725-10-00-01-0
WP6000 WR	Welded	2890-6000 mm	0-180°	50 kg	100 kg	R	WSG-0725-10-00-02-0
WP6000 BL	Bolted	2840-5980 mm	0-180°	50 kg	110 kg	L	WSG-0745-10-00-00-0
WP6000 BR	Bolted	2890-6030 mm	0-180°	50 kg	110 kg	R	WSG-0745-10-00-01-0

Free-standing pillar

A free-standing pillar is used to mount both a telescopic and pivot wire feeder boom in an open space within a room or hall, in a location where it is not possible to mount the boom on a hall pillar or wall.

The free-standing pillar is installed using floor anchors.

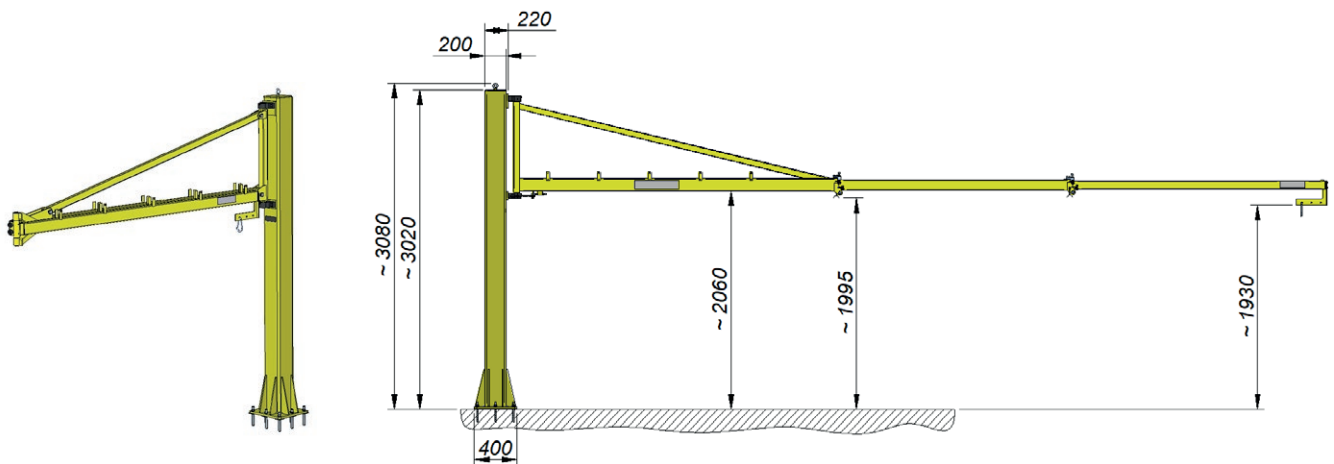

A free-standing pillar is the ideal solution for mounting either telescopic or pivot wire feeder boom in an open space within a room or hall.

Types of holders

Each telescopic and pivot wire feeder boom comes with a specific type of holder either "R" or "L".

To increase the functionality of the booms, their current design allows the users to replace the original holder with another holder variant even after purchase. Both the ,R' and ,L' brackets are mounted in the same way (see below), so users are able to swap them themselves.

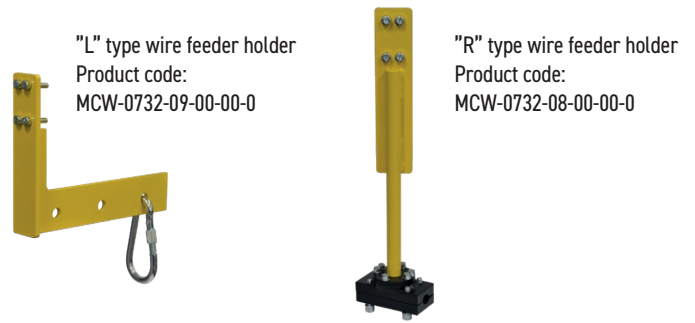

Hydraulic wire feeder boom

- can be rotated up to 360° around the vertical axis
- adjustable height of the boom from 1300 mm (51") up to 3430 mm (135")

Product code: WSG-000003

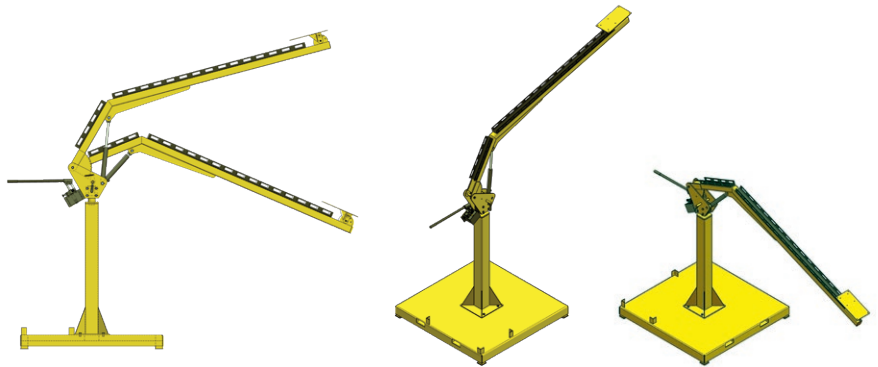
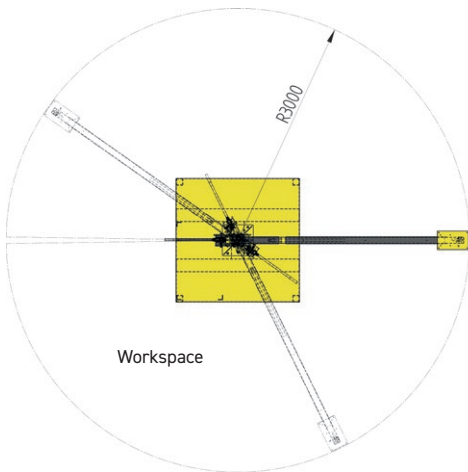
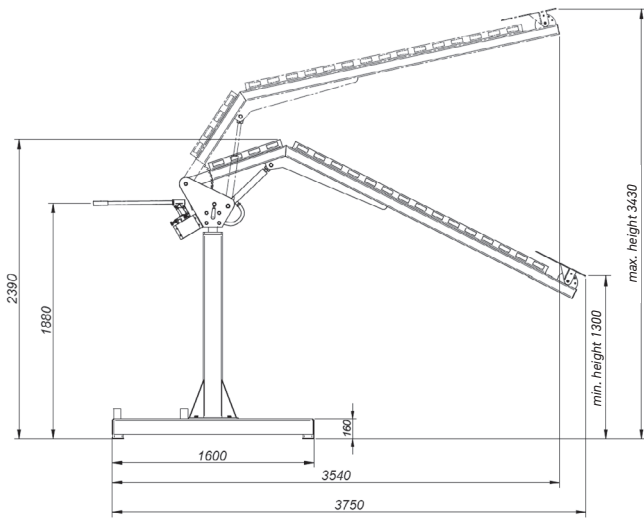

HYDRAULIC WIRE FEEDER BOOM Technical specifications	
Reach	3000 mm (118")
Lifting height	1300 – 3430 mm (51 – 135")
Rotation angle	0-360°
Maximum load (wire feeder, wire)	50 kg (110 lbs)
Dimensions [L x W x H]	3750 mm x 1600 mm x 2390 mm (min) / 3430 mm (max) 148" x 63" x 94" (min) / 135" (max)
Weight	330 kg (733 lbs)

RWCA | ROBOTIZED WELDING / CUTTING ARM

The RWCA is a robotic welding arm equipped with an advanced manipulator, enabling welding applications far beyond the capabilities of conventional welding arms.

This system allows for welding of curved joints or lines oriented in 3D space without the need to reposition the workpiece.

It is particularly well-suited for spatial structures, including joints in areas inaccessible to traditional solutions.

An optional plasma cutting kit is also available for increased versatility.

■ Main features and benefits:

- Virtually unlimited welding positions and path geometries using MIG/MAG technologies
- Capable of welding complex, multi-component structures with high precision
- Consistent, repeatable, high-quality welds for improved reliability and performance
- Touch sensing functionality for accurate joint position detection before welding
- Path tracking capability to maintain optimal torch positioning during welding
- Customizable working range – The manipulator's reach and track length can be tailored to specific customer needs by adjusting the arm height or mounting the system on a mobile base for longer components
- The RWCA delivers high flexibility and precision, making it an ideal solution for demanding industrial welding and cutting tasks.

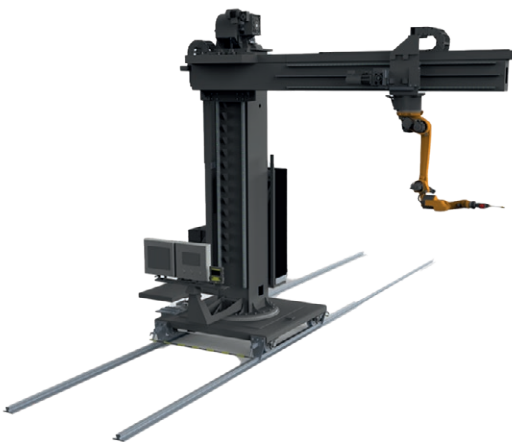

■ Installations worldwide

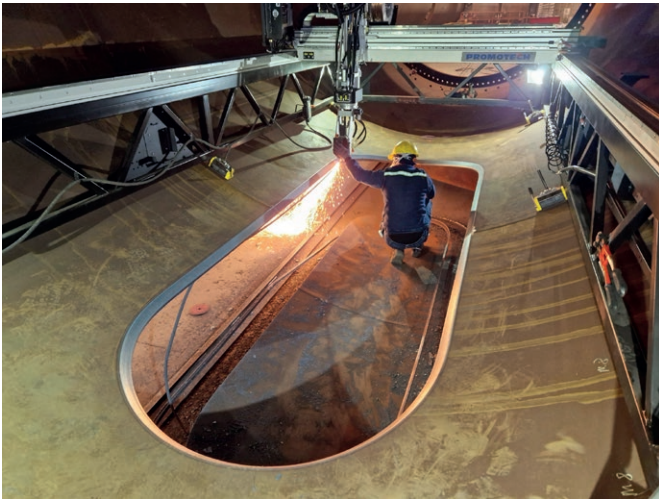

■ Workshops and training sessions

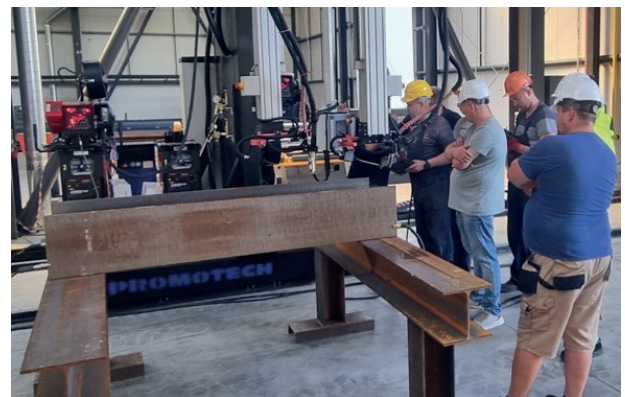

■ Product Service



Reference visits



Participation in trade fairs

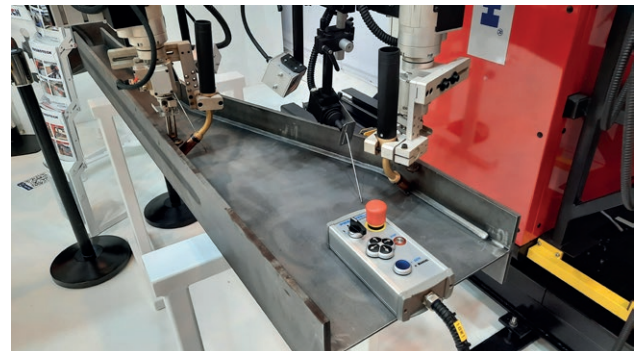

Stay connected



Follow us on our social media to discover how our machines and solutions can boost your industrial processes



- Expert insights
- Hands-on knowledge
- Industry trends & innovations
- Inspiring applications
- Real-world case studies
- Tips & tricks
- and more



PROMOTECH International

Don't miss a thing



PRO-40 PBS | Stationary Pipe Beveling Machine



SCORPIO BATTERY: Advanced Battery-Powered Welding Tractor



ABM-50 DD Vario | Auto-Feed Heavy Duty Beveler



PROMOTECH MCM | 5-Axis CNC Machine- Revolutionize Wind Tower Door Frame...

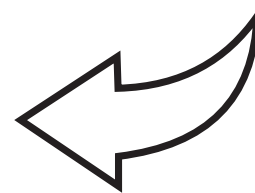

Check our **BLOG** for expert insights, practical guides and product news

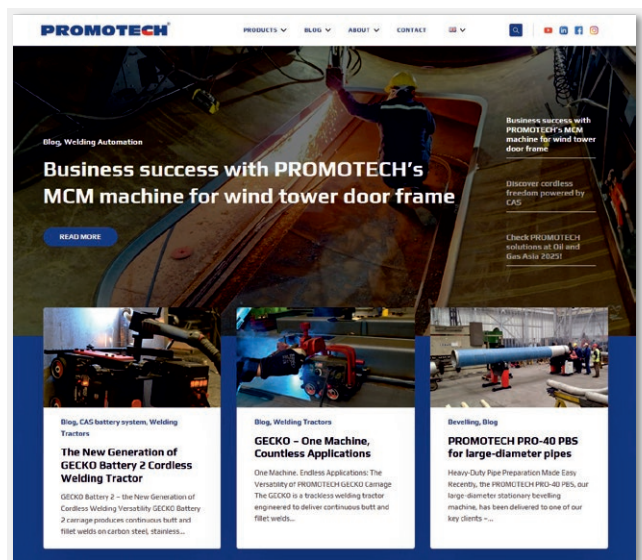

PROMOTECH DEUTSCHLAND GmbH
Riedweg 11
D-88339 Bad Waldsee/Gaisbeuren
DEUTSCHLAND

Phone: +49 7524 9700-55
dach@pdg.promotech.eu
www.promotech-deutschland.de

PROMOTECH ME (FZE)
P6-111, Saif Zone
P.O. Box. 514914
Sharjah, UAE

Phone: +9716 552 9493
akumar@pme.promotech.eu
www.promotechme.ae

PROMOTECH Fabrication Machines Pvt. Ltd.
Head Office: Plot 231, Phase-5, Sector 53
I/E HSIIDC Kundli, Sonipat
Haryana-131028, INDIA

Phone: +91 966 766 0304
info@pfm.promotech.eu
www.promotech-india.in

PROMOTECH ITALY
Via Della Resistenza, 34/F
20090 Buccinasco (MI)
ITALY

Phone: + 39 02 8457 1800
davide.beltrami@ssqmotori.it
www.promotech.eu/it/

PROMOTECH®

PROMOTECH Sp. z o.o.
ul. Elewatorska 23/1
15-620 Białystok
POLAND

Phone: +48 85 678 34 05
marketing@promotech.eu
www.promotech.eu

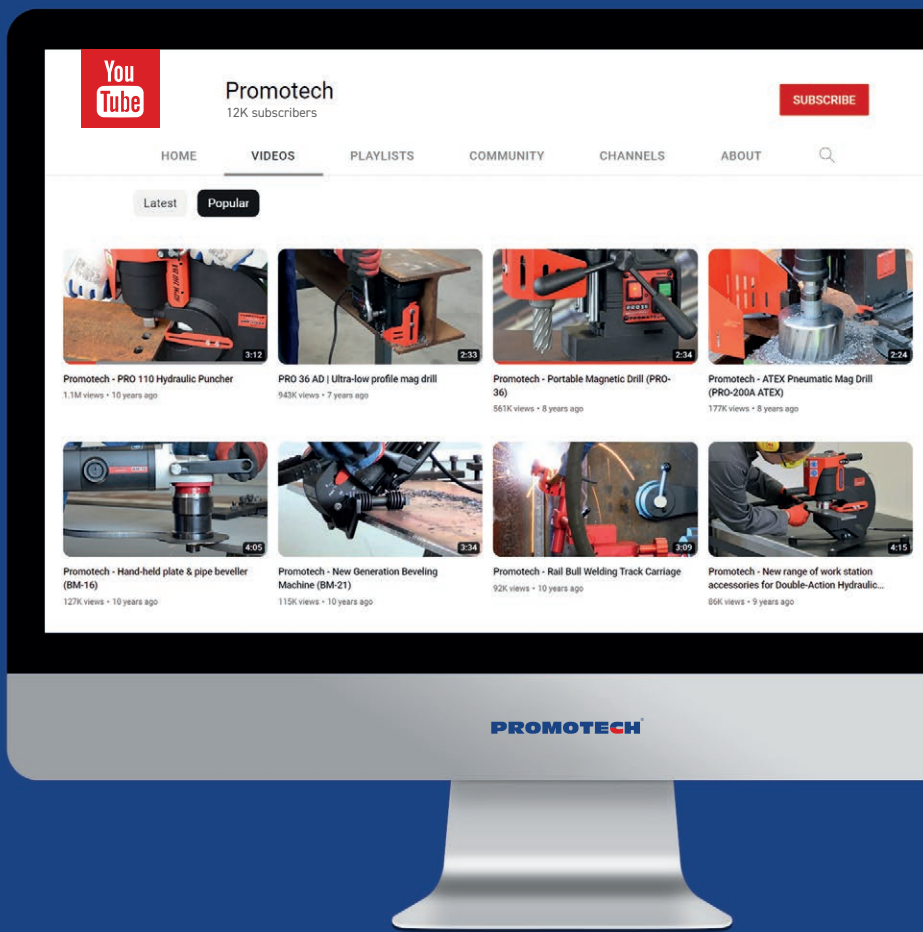

FOLLOW US FOR UPDATE & MORE

www.promotech.eu

PROMOTECH®



Mitglied im DVS - Deutscher Verband für Schweißen und verwandte Verfahren e. V.



Your local dealer: