



PROMOTECH[®]

MCM 5-AXIS MACHINE

for mechanised installation
of wind tower door frames

ALL in ONE SOLUTION

**SCANNING
CUTTING
BEVELLING
INSIDE WELDING
ON TOP WELDING**

www.promotech.eu

EASY WIND TOWER ENTRANCE DOOR FRAME INSTALLATION WITH PROMOTECH MCM



Unlike typical robotics solutions, PROMOTECH MCM system does not require:

- complex CNC programming
- highly skilled operators
- additional CAD/CAM software
- costly optical seam tracking
- costly and troublesome automatic flux handling equipment

For over 10 years PROMOTECH has been manufacturing this unique MCM solutions that manages to significantly increase the entire efficiency of door frame installation into wind towers.

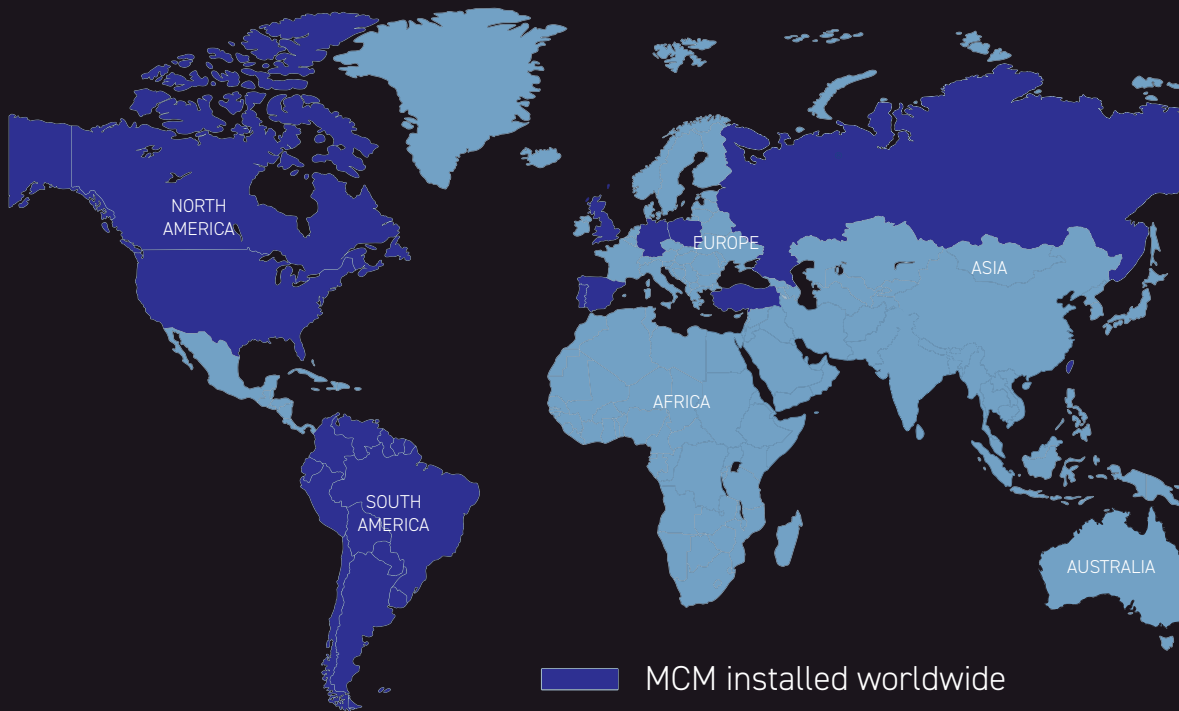

MCM is a 5-axis portable CNC scanning, cutting, bevelling, and welding machine that enables **remarkable precision** and a major **reduction in welding time** and **reduction welding materials**. It offers new efficiency which can redefine your business operations in wind tower manufacturing.

MCM can be up to 6 metres long and 3 metres wide and allows to insert the wind tower door frames up to 1400 mm wide and 4500 mm high. It is a multitask – cutting/bevelling and welding solution, so all multi-pass work may be done with one machine and one operator and in one set up.

How is PROMOTECH MCM better than the manual welding?

For those companies that still hold on to using traditional, time-consuming manual processes, the primary challenge is the time- and money-consuming factor of the door frame process. The curvature of the door frame shape is never 100% identical, so without MCM it is difficult to ensure much required accuracy and repeatability. Then, remember that the typical frame is at least 2-inch thick and thus, obviously, difficult to handle.

	Current technology	PROMOTECH MCM
Assumptions	metal plate thickness 60 mm door frame size 1000 x 4000 mm	metal plate thickness 60 mm door frame size 1000 x 4000 mm
Welding method	manual GMAW/FCAW/MCAW	SAW Single Wire
Welding current	max 300A	550A - 750A
Deposition rate	1.5 - 3 kg/hour (arc time 30%)	up to 9 - 12 kg/hour (at arc time 90%)
Welding wire diameter	1.2 mm	4.0 mm
Welding speed	up to 25-30 cm/min	up to 60 cm/min
TIME	Manual cutting and welding: 200 hrs. +	MCM cutting and welding: 40 hrs.
Defect rate	...	less than 1%

PROMOTECH MCM is a 5-axis portable CNC scanning, cutting, beveling and welding machine enabling multi-pass works to be done in one setup and by a single operator.

- MCM enables **remarkable precision** of cutting and beveling laying the foundation for high quality welds.
- The mechanization of **multi-pass SAW welding** significantly **reduces the process** time of wind tower door frame assembly and improves overall productivity, eliminating the biggest bottleneck in the production of steel wind towers.
- The customer can choose from a range of MCM models. The largest MCM can handle door frames up to 1400 mm wide and 4500 mm high.
- System already **proven with leading tower manufacturers** on all continents **for a number of years**. Many of our customers enjoy having more than one MCM installed.





SCANNING

Laser scanning for perfect alignment!

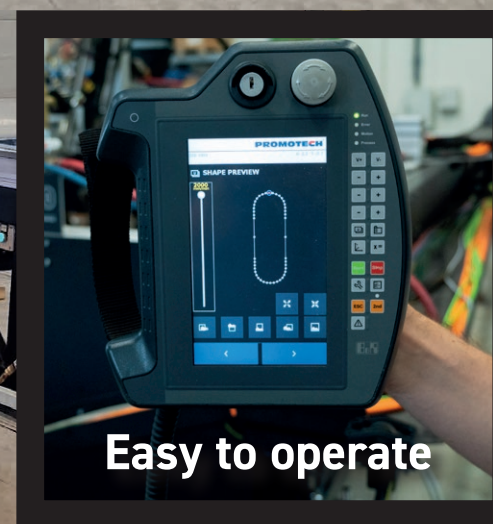
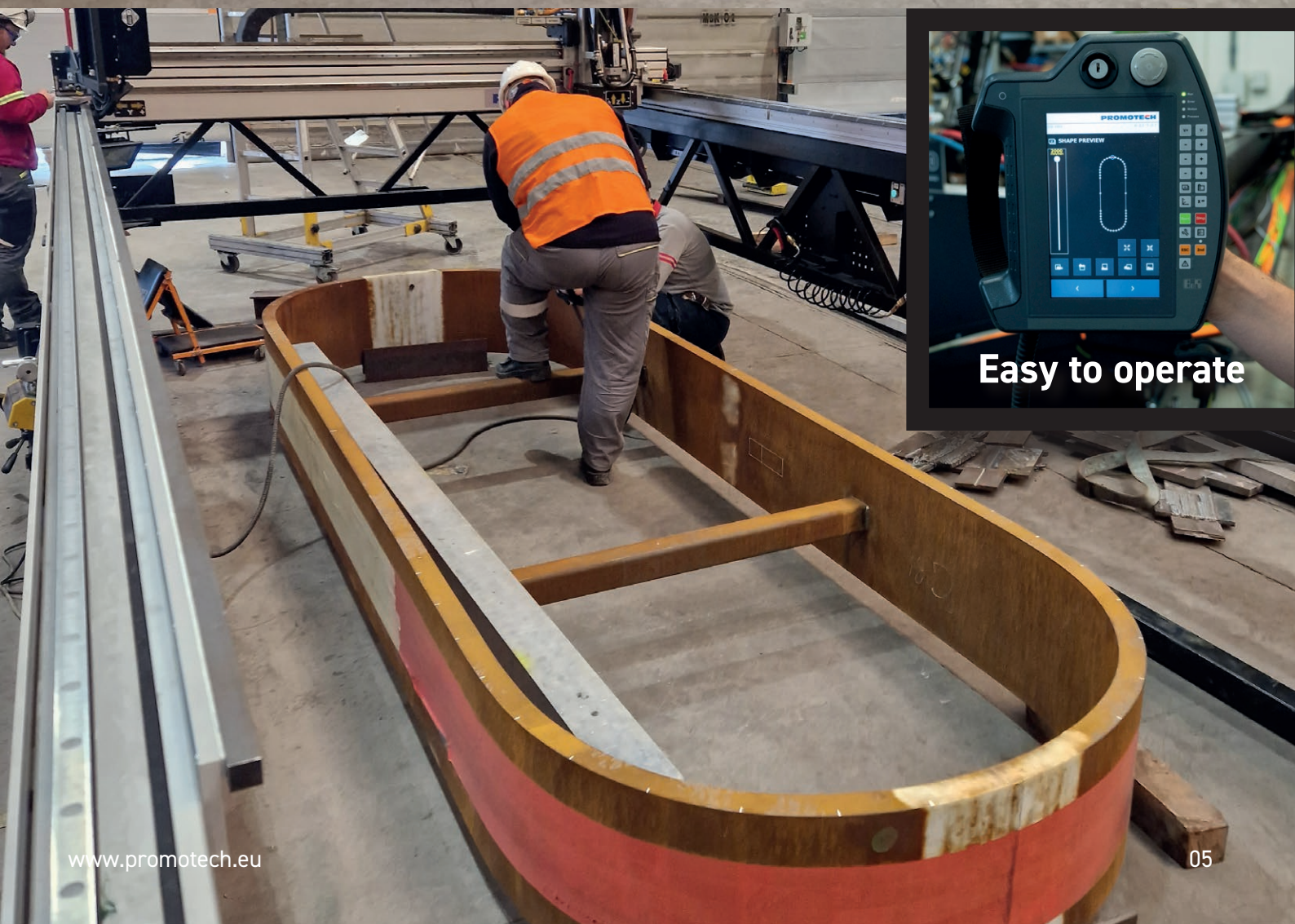

Easy to operate



CUTTING

Fast & Precise

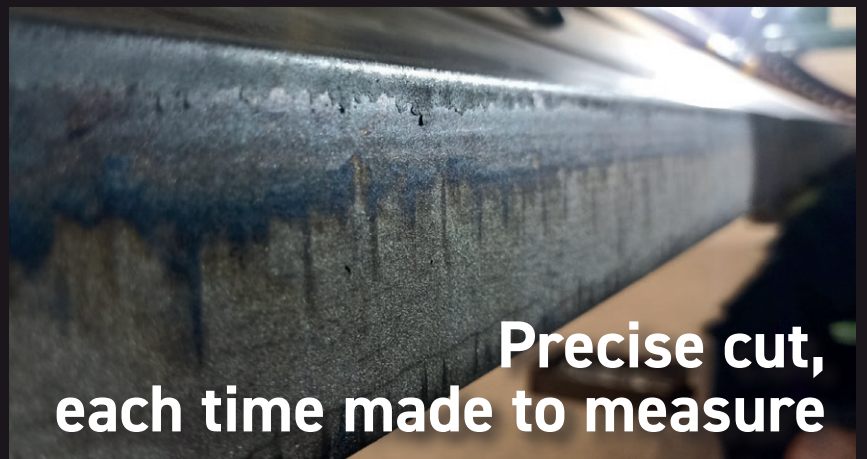
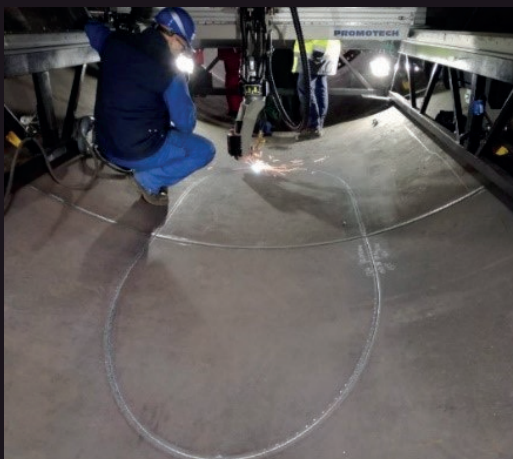
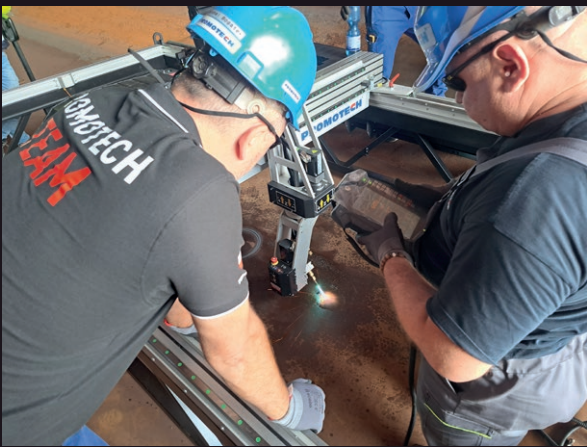

Precise cut,
each time made to measure



BEVELLING

No need for grinding!



Perfect bevel



INSIDE WELDING

Seriously reduced use of consumables.
Uninterrupted workflow - operates 24/7



Top quality welding



ONLY FOR MCM MAX LOAD 1000 kg

ON TOP WELDING

Minimized downtime. Welding defect less than 1%



Perfect result
- no welding errors

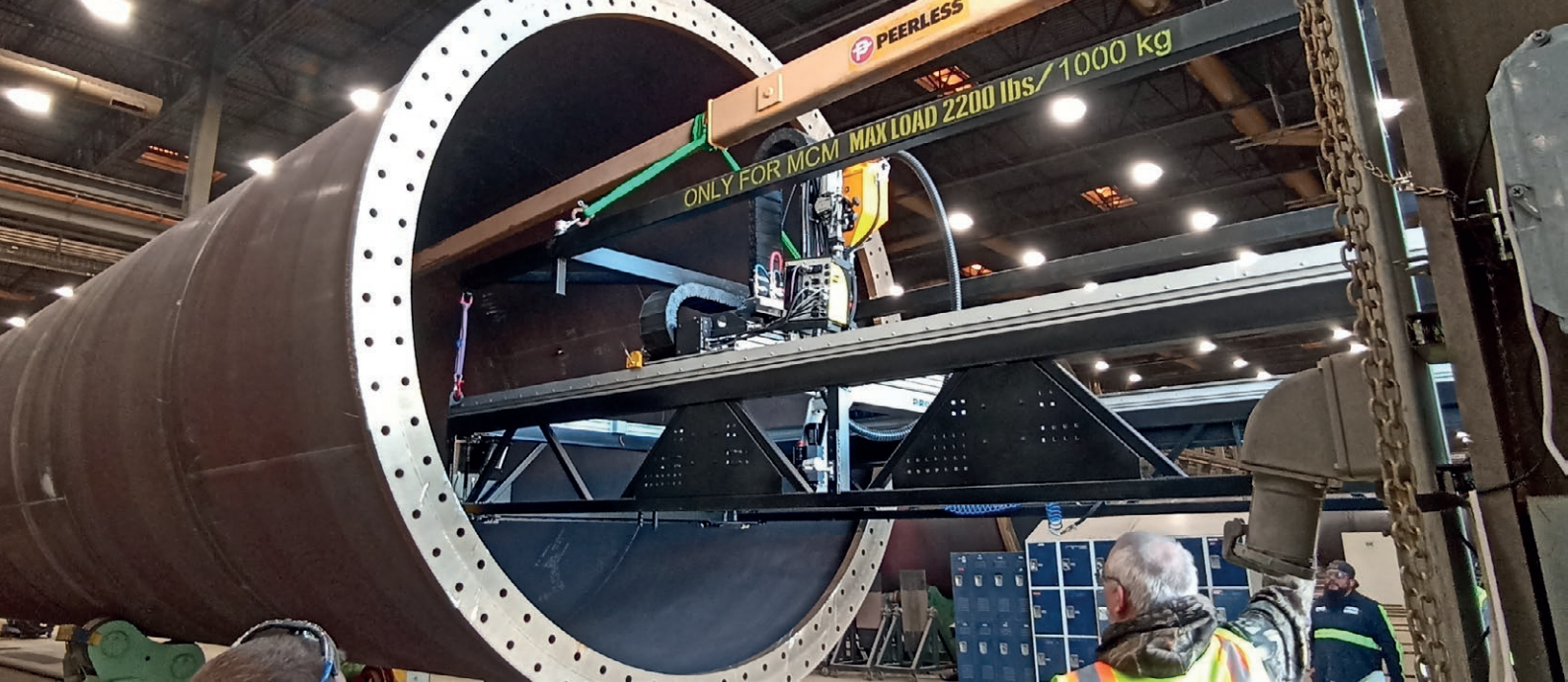

PROMOTECH MCM comes with **worldwide warranty and post-warranty service**. To enhance full customer support, all MCM machines come equipped with a built-in network router. This feature enables with the owners clear consent, PROMOTECH's remote access to the MCM interface, allowing its engineers to perform diagnostics, troubleshooting, and upload software updates when requested. Thus, addressing any concerns promptly, **minimizing downtime and maximizing productivity**.



PARAMETERS

MODEL/PARAMETER		MCM Mini	MCM 1000	MCM 4000 S	MCM 4000 XW	MCM 4000 TW	MCM 4500
Overall dimensions	L [mm]	4340	4340	6240	6240	6260	6860
	W [mm]	2460	2460	2850	3000	3350	3050
	H [mm]	2070	2070	2150	2270	2150	2190
Range of straight cut hole		1000 x 2200		1600 x 4400	1700 x 4400	2100 x 4400	1800 x 4900
Range of bevelled hole				1300 x 4100	1400 x 4100	1800 x 4100	1500 x 4600
Range of welded hole				1200 x 4000	1300 x 4000	1700 x 4000	1450 x 4500
Minimum inner diameter of the section [ϕ D1 mm]		3000	3500	3900	4000	4900	4300
Minimum distance of the frame from the flange [mm]		N/A	N/A	600	600	600	600
Weight of the machine without equipment [kg]		720	720	950	980	1070	1050
Maximum process speed (single axis) [mm/min]		2000					
Maximum bevel angle [°]		45					
Maximum welding angle [°]		30					
Power [W]		1500					
Voltage [V, Hz]		3~ 380-480VAC + PE (\pm 10%) 50/60Hz					
Number of numerically controlled axes		5					

* With large thicknesses (above 80mm), the working ranges are reduced - this should be considered individually

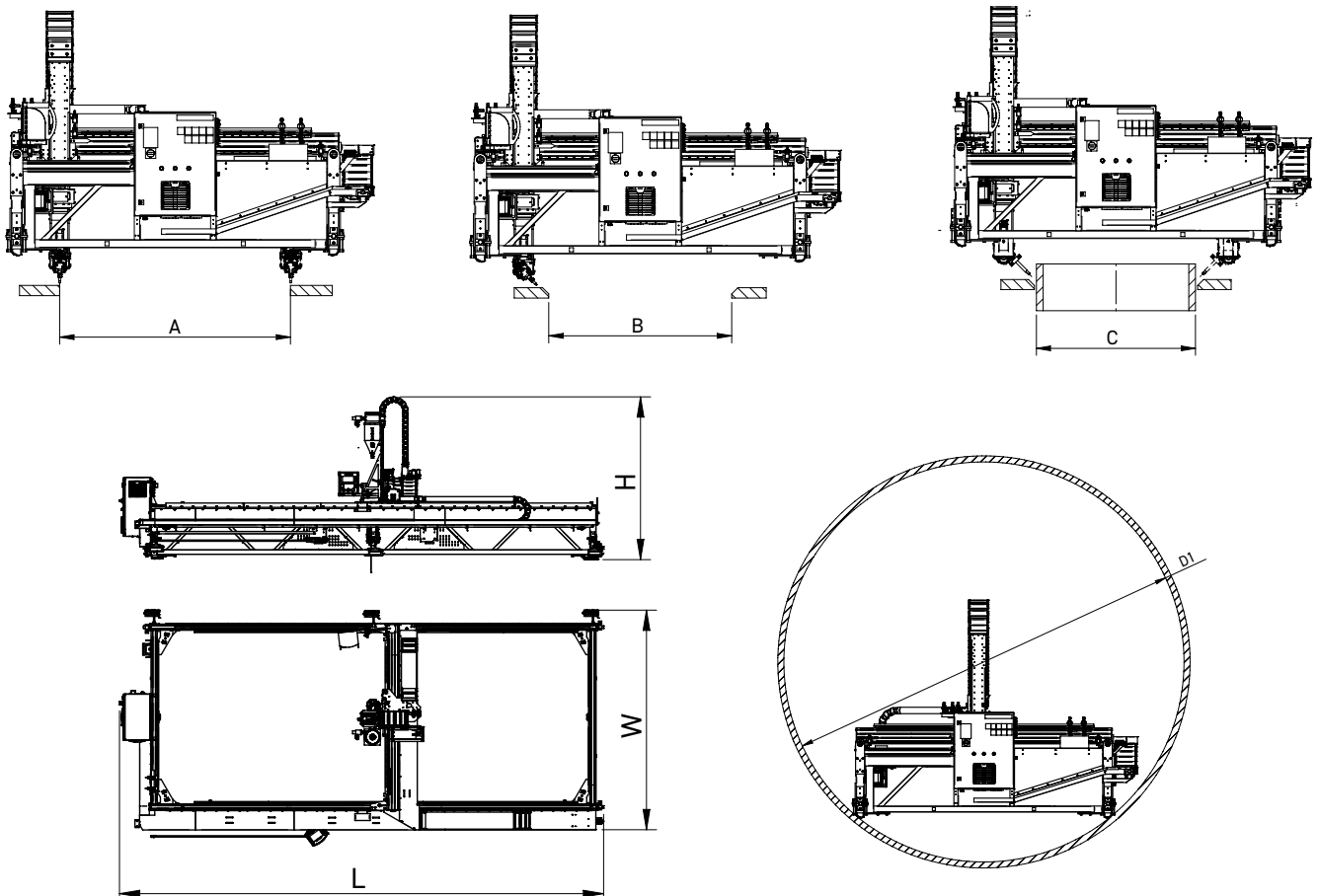

All information is subject to change without notice. 26.04



One-Man operation!

Eliminates the biggest bottleneck in the tubular steel wind tower production!
Welding door frame at #60mm of tower plate thickness within 3-4 shifts.



No need for grinding!

Increased productivity.
Unmatched efficiency & repeatability.
Welding defect rate much less than 1%



Onshore & Offshore!

Excellent Return On Investment (ROI).
System already proven with Clients in the Wind Business.



PROMOTECH Sp. z o.o.
ul. Elewatorska 23/1
15-620 Białystok, POLAND

Tel. +48 85 678 34 95
marketing@promotech.eu
www.promotech.eu

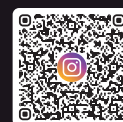

FOLLOW US FOR UPDATE AND MORE

More information available at www.promotech.eu