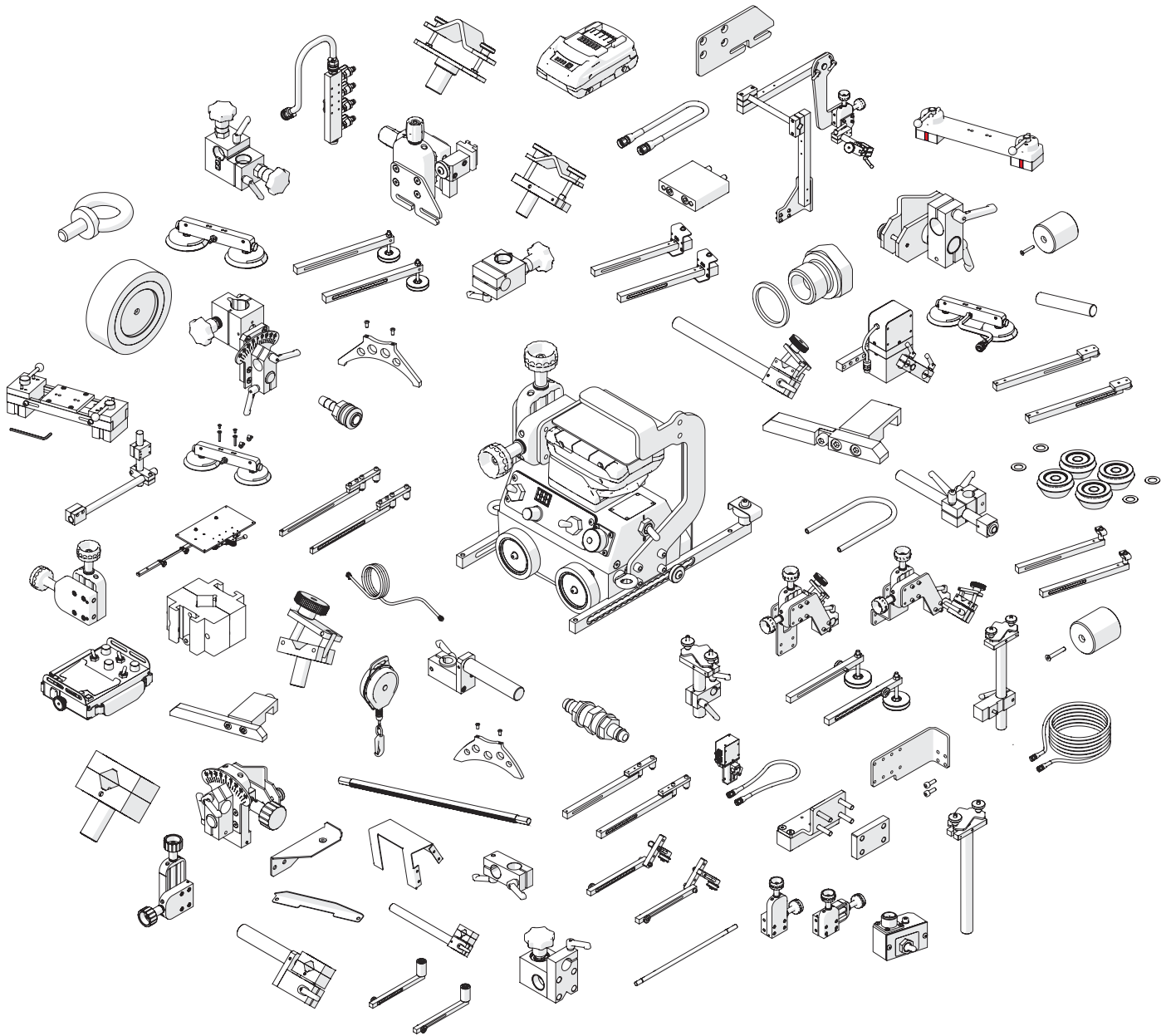


# PROMOTECH®

*smart tools for heavy tasks*

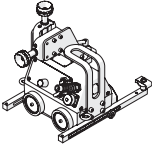
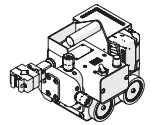


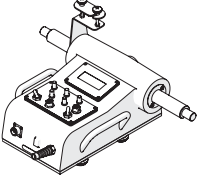
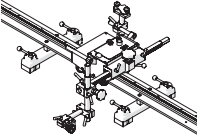
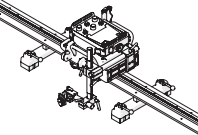
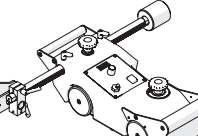
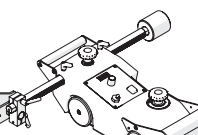
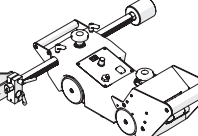
[promotech.eu](http://promotech.eu)

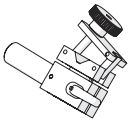
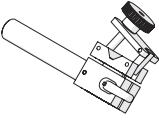
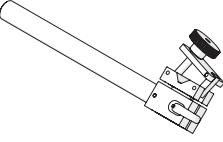
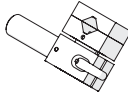
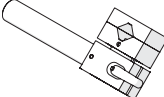
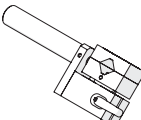
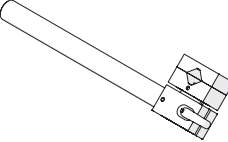
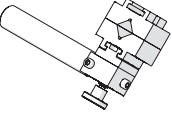
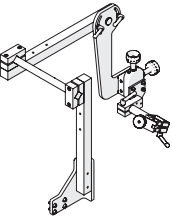
**WELDING & CUTTING  
ACCESSORIES**

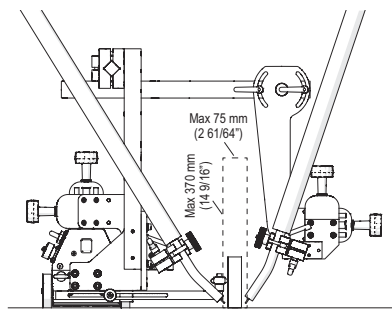
CATALOGUE

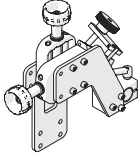
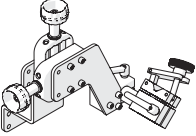
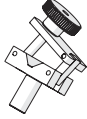
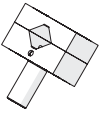
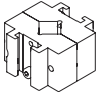

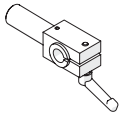
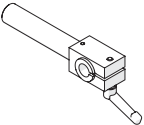
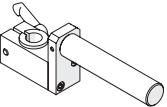
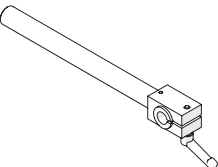
TABLE OF CONTENT		Page
I.	<a href="#">WELDING &amp; CUTTING TRACTORS</a>	1-2
II.	<a href="#">WELDING TORCH HOLDERS AND MATCHING ACCESSORIES</a>	3-5
III.	<a href="#">CUTTING TORCH HOLDERS AND MATCHING ACCESSORIES</a>	6-7
IV.	<a href="#">MANIFOLDS</a>	8
V.	<a href="#">CUTTING - MISCELLANEOUS</a>	9
VI.	<a href="#">PLASMA CUTTING</a>	9
VII.	<a href="#">POWER SUPPLIES, BATTERIES, CHARGERS, CABLES</a>	10
VIII.	<a href="#">CROSS SLIDES</a>	11
IX.	<a href="#">CABLE ANCHORS</a>	12
X.	<a href="#">COVERS &amp; SHIELDS</a>	13
XI.	<a href="#">TRACKS &amp; MATCHING ACCESSORIES FOR WHEEL TRACTORS</a>	14-15
	<a href="#">160 mm WIDE FLEXIBLE TRACK configuration diagram</a>	16
XII.	<a href="#">GUIDE ARMS FOR WHEEL TRACTORS</a>	17-18
XIII.	<a href="#">MAGNET BLOCKS FOR WHEEL TRACTORS</a>	19
XIV.	<a href="#">DRIVE WHEELS</a>	19
XV.	<a href="#">TRACKS &amp; MATCHING ACCESSORIES FOR RAIL TRACTORS</a>	20-27
	<a href="#">RING TRACKS</a>	23
	<a href="#">HI-FLEX TRACK configuration diagram</a>	25
	<a href="#">SEMI-FLEXIBLE TRACK configuration diagram</a>	26
	<a href="#">RIGID TRACK configuration diagram</a>	27
	<a href="#">V-TRACK configuration diagram</a>	27
XVI.	<a href="#">SEAM TRACKING FOR RAIL TITAN 2</a>	28
XVII.	<a href="#">CONTROL PANEL &amp; CABLES</a>	29
XVIII.	<a href="#">TRANSPORT ATTACHMENTS</a>	29
XIX.	<a href="#">VACUUM TRACK SYSTEM</a>	30-31
XX.	<a href="#">PENDULUM OSCILLATION</a>	32, 45
XXI.	<a href="#">INDIVIDUAL ACCESSORIES DESIGNED FOR SPECIFIC TRACTORS</a>	33-37
XXII.	<a href="#">ALPHABETICAL INDEX OF ACCESSORIES</a>	38-40
XXIII.	<a href="#">TRACTOR CONFIGURATION DIAGRAMS</a>	41-46
	<a href="#">DRAGON configuration diagram I</a>	41
	<a href="#">DRAGON configuration diagram II</a>	42
	<a href="#">RAIL TITAN 2 configuration diagram</a>	43
XXIV.	<a href="#">JTS - JOINT TRACKING SYSTEM</a>	44
XXV.	<a href="#">OSC-8 PRO - PENDULUM OSCILLATOR</a>	45
XXVI.	<a href="#">SWSO - ORBITAL WELDING SUPPORT SYSTEM</a>	47

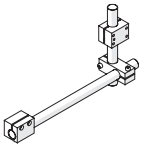
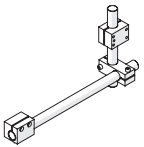





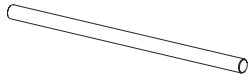
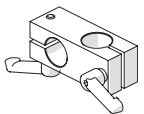

Product	Product Code / Description	Specification
	WOZ-0752-10-20-02-0 GECKO	• EU plug
	WOZ-0752-10-20-03-0 GECKO	• UK plug
	WOZ-0777-10-04-01-0 GECKO 42V	• 42V
	WOZ-0772-10-20-03-0 GECKO HS	• EU plug
	WOZ-0772-10-20-04-0 GECKO HS	• UK plug
	WOZ-0778-10-04-01-0 GECKO HS 42V	• 42V
	WOZ-0805-10-00-00-0 GECKO Battery 2	<ul style="list-style-type: none"> <li>• the set includes the carriage and 2 pcs. of battery 4.0 Ah</li> <li>• battery charger to be bought separately</li> </ul>
	WOZ-0759-10-00-00-0 MINI SPIDER Battery	<ul style="list-style-type: none"> <li>• the set includes the carriage and 2 pcs. of battery 4.0 Ah</li> <li>• battery charger to be bought separately</li> </ul>
	WOZ-0757-10-00-00-0 SCORPIO Battery	<ul style="list-style-type: none"> <li>• the set includes the carriage and 2 pcs. of battery 4.0 Ah</li> <li>• battery charger to be bought separately</li> </ul>
	WOZ-0824-10-18-00-0 MANTIS Battery	<ul style="list-style-type: none"> <li>• the set includes the carriage and 1 pc. of battery 4.0 Ah</li> <li>• battery charger to be bought separately</li> <li>• profile clamps to be bought separately</li> </ul>
	WOZ-0754-10-20-02-0 LIZARD	• EU plug
	WOZ-0754-10-20-03-0 LIZARD	• UK plug
	WOZ-0784-10-42-01-0 LIZARD 42V	• 42V


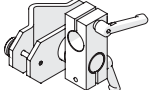
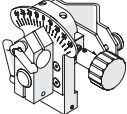
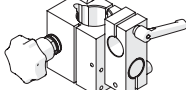
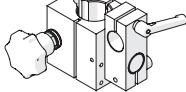
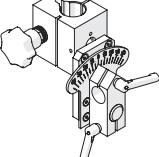
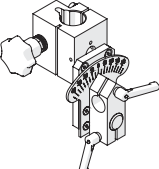
Product	Product Code / Description	Specification
	WOZ-0760-10-20-00-0 RAIL BULL	• EU plug
	WOZ-0760-10-20-01-0 RAIL BULL	• UK plug
	WOZ-0624-10-04-00-0 RAIL BULL 42V	• 42V
	WOZ-0570-10-20-01-0 RAIL TUG	• EU plug
	WOZ-0813-10-20-00-0 RAIL TITAN 2	• EU plug
	WOZ-0820-10-04-00-0 RAIL TITAN 2 42V	• 42V
	WOZ-0753-10-20-02-0 DRAGON	• EU plug
	WOZ-0753-10-20-03-0 DRAGON	• UK plug
	WOZ-0787-10-04-01-0 DRAGON 42V	• 42V
	WOZ-0786-10-20-02-0 DRAGON HS	• EU plug
	WOZ-0786-10-20-03-0 DRAGON HS	• UK plug
	WOZ-0788-10-00-00-0 DRAGON Battery	<ul style="list-style-type: none"> <li>• the set includes the carriage and 2 pcs. of battery 4.0 Ah</li> <li>• battery charger to be bought separately</li> </ul>






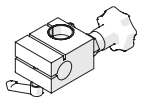
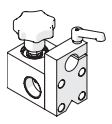
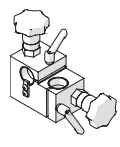
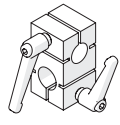
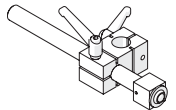
Product	Product Code / Description	Specification
	UCW-0757-09-00-00-0 Ultra-short rod torch holder with clamp 16–22 mm	<ul style="list-style-type: none"> <li>• clamp for welding torches ranged 16-22 mm OD</li> <li>• dowel pin 15 mm OD</li> <li>• rod 60 mm long/ 22.2 mm OD</li> <li>• clamping block 22.2 mm ID with lever</li> <li>• insulation tube 22.2 mm OD/15 mm ID</li> </ul>
	UCW-0754-07-00-00-0 Short rod torch holder with clamp 16–22 mm	<ul style="list-style-type: none"> <li>• clamp for welding torches ranged 16-22 mm OD</li> <li>• dowel pin 15 mm OD</li> <li>• rod 110 mm long/ 22.2 mm OD</li> <li>• clamping block 22.2 mm ID with lever</li> <li>• insulation tube 22.2 mm OD/15 mm ID</li> </ul>
	UCW-0752-07-00-00-0 Long rod torch holder with clamp 16–22 mm	<ul style="list-style-type: none"> <li>• clamp for welding torches ranged 16-22 mm OD</li> <li>• dowel pin 15 mm OD</li> <li>• rod 230 mm long/ 22.2 mm OD</li> <li>• clamping block 22.2 mm ID with lever</li> <li>• insulation tube 22.2 mm OD/15 mm ID</li> </ul>
	UCW-0757-12-00-00-0 Ultra-short rod torch holder with clip 16–22 mm	<ul style="list-style-type: none"> <li>• clip for welding torches ranged 16-22 mm OD</li> <li>• dowel pin 15 mm OD</li> <li>• rod 60 mm long/ 22.2 mm OD</li> <li>• clamping block 22.2 mm ID with lever</li> <li>• insulation tube 22.2 mm OD/15 mm ID</li> </ul>
	UCW-0476-27-00-00-0 Short rod torch holder with clip 16–22 mm	<ul style="list-style-type: none"> <li>• clip for welding torches ranged 16-22 mm OD</li> <li>• dowel pin 15 mm OD</li> <li>• rod 110 mm long/ 22.2 mm OD</li> <li>• clamping block 22.2 mm ID with lever</li> <li>• insulation tube 22.2 mm OD/15 mm ID</li> </ul>
	UCW-0476-06-00-00-0 Short low rod torch holder with clip 16–22 mm	<ul style="list-style-type: none"> <li>• clip for welding torches ranged 16-22 mm OD</li> <li>• dowel pin 15 mm OD</li> <li>• low rod 110 mm long/ 22.2 mm OD</li> <li>• clamping block 22.2 mm ID with lever</li> <li>• insulation tube 22.2 mm OD/15 mm ID</li> <li>• for use with, among others, a pendulum oscillator</li> </ul>
	UCW-0466-22-00-00-0 Long rod torch holder with clip 16–22 mm	<ul style="list-style-type: none"> <li>• clip for welding torches ranged 16-22 mm OD</li> <li>• dowel pin 15 mm OD</li> <li>• rod 230 mm long/ 22.2 mm OD</li> <li>• clamping block 22.2 mm ID with lever</li> <li>• insulation tube 22.2 mm OD/15 mm ID</li> </ul>
	UCW-0523-84-00-00-0 Quick-release short rod torch holder with clip 16–22 mm	<ul style="list-style-type: none"> <li>• quick-release clip for welding torches ranged 16-22 mm OD</li> <li>• swivel cube with grooves</li> <li>• spring lock</li> <li>• rod 110 mm long/ 22.2 mm OD</li> </ul>
	PDT-0466-40-00-00-0 Dual torch mount	<ul style="list-style-type: none"> <li>• max web height – 370 mm</li> <li>• max web thickness – 75 mm</li> </ul>

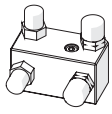
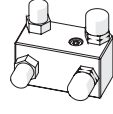
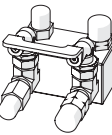
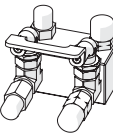
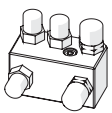
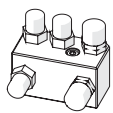
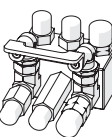
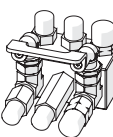
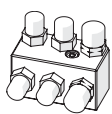
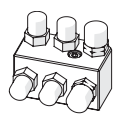
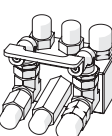
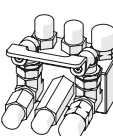
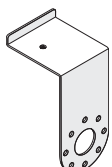
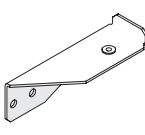


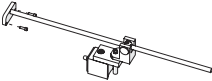
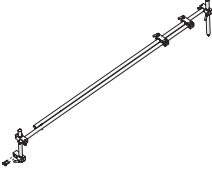

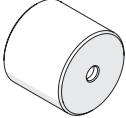
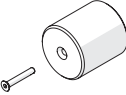
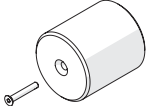
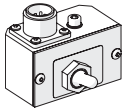

Product	Product Code / Description	Specification
	UKL-0752-26-00-00-0 Assembly for mounting a second torch in GECKO	<ul style="list-style-type: none"> <li>• clamp for welding torches ranged 16-22 mm OD</li> <li>• dowel pin 15 mm OD</li> <li>• rod 60 mm long/ 22.2 mm OD</li> <li>• clamping block 22.2 mm ID with lever</li> <li>• insulation tube 22.2 mm OD/15 mm ID</li> <li>• 0-35 mm up and down adjustment</li> <li>• 0-35 mm left and right adjustment</li> <li>• straight bracket</li> </ul>
	UKL-0752-25-00-00-0 Assembly for mounting a third torch in GECKO	<ul style="list-style-type: none"> <li>• clamp for welding torches ranged 16-22 mm OD</li> <li>• dowel pin 15 mm OD</li> <li>• rod 60 mm long/ 22.2 mm OD</li> <li>• clamping block 22.2 mm ID with lever</li> <li>• insulation tube 22.2 mm OD/15 mm ID</li> <li>• 0-35 mm up and down adjustment</li> <li>• 0-35 mm left and right adjustment</li> <li>• bent bracket</li> </ul>
	ZRZ-0752-07-01-00-0 Torch clamp 16-22 mm	<ul style="list-style-type: none"> <li>• clamp for welding torches ranged 16-22 mm OD</li> <li>• dowel pin 15 mm OD</li> </ul>
	ZCS-0476-06-01-00-0 Torch clip 16-22 mm	<ul style="list-style-type: none"> <li>• clip for welding torches ranged 16-22 mm OD</li> <li>• dowel pin 15 mm OD</li> </ul>
	ZCS-0270-42-00-00-0 Quick-release torch clip 16-22 mm	<ul style="list-style-type: none"> <li>• clip for welding torches ranged 16-22 mm OD</li> <li>• quick-release mount</li> </ul>
	ZRZ-0466-19-00-00-0 Torch clamp 22-35 mm	<ul style="list-style-type: none"> <li>• clamp for welding torches ranged 22-35 mm OD</li> <li>• dowel pin 15 mm OD</li> </ul>
	WLK-0757-09-01-00-0 Ultra-short rod clamp	<ul style="list-style-type: none"> <li>• rod 60 mm long/ 22.2 mm OD</li> <li>• clamping block 22.2 mm ID with lever</li> <li>• insulation tube 22.2 mm OD/15 mm ID</li> </ul>
	WLK-0476-20-01-00-0 Short rod clamp	<ul style="list-style-type: none"> <li>• rod 110 mm long/ 22.2 mm OD</li> <li>• clamping block 22.2 mm ID with lever</li> <li>• insulation tube 22.2 mm OD/15 mm ID</li> </ul>
	TRM-0476-06-10-00-0 Lower rod clamp	<ul style="list-style-type: none"> <li>• rod 110 mm long/ 22.2 mm OD</li> <li>• low clamping block 22.2 mm ID with lever</li> <li>• insulation tube 22.2 mm OD/15 mm ID</li> </ul>
	WLK-0466-04-10-00-0 Long rod clamp	<ul style="list-style-type: none"> <li>• rod 230 mm long/ 22.2 mm OD</li> <li>• clamping block 22.2 mm ID with lever</li> <li>• insulation tube 22.2 mm OD/15 mm ID</li> </ul>


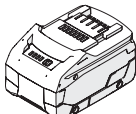
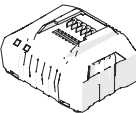


Product	Product Code / Description	Specification
	PRD-0466-43-00-00-0 Torch extension arm for GECKO family and LIZARD	<ul style="list-style-type: none"> <li>• block for attaching to tractor with 4 screws M5 x 16</li> <li>• rod 380 mm long / 22.2 mm OD</li> <li>• block with two holes 22.2 mm ID</li> <li>• rod 150 mm long/ 22.2 mm OD</li> <li>• block for attaching the cross-slide</li> <li>• increases the reach of the torch</li> <li>• enables repositioning and moving the cross-slide away from the tractor</li> <li>• suitable for GECKO family and LIZARD</li> </ul>
	PRD-0757-10-00-00-0 Torch extension arm for SCORPIO Battery	<ul style="list-style-type: none"> <li>• block for attaching to tractor</li> <li>• rod 380 mm long / 22.2 mm OD</li> <li>• block with two holes 22.2 mm ID</li> <li>• rod 150 mm long/ 22.2 mm OD</li> <li>• block for attaching the cross-slide with 4 screws M5 x 10</li> <li>• increases the reach of the torch</li> <li>• enables repositioning and moving the cross-slide away from the tractor</li> <li>• suitable for SCORPIO Battery</li> </ul>
	SLP-0233-13-02-00-1 150 mm long rod	<ul style="list-style-type: none"> <li>• rod 150 mm long/ 22.2 mm OD</li> </ul>
	KLM-0236-00-16-00-0 200 mm long rod	<ul style="list-style-type: none"> <li>• rod 200 mm long/ 22.2 mm OD</li> </ul>
	WSP-0523-16-00-00-0 300 mm long rod	<ul style="list-style-type: none"> <li>• rod 300 mm long/ 22.2 mm OD</li> </ul>
	WLK-0633-22-04-00-0 400 mm long rod	<ul style="list-style-type: none"> <li>• rod 400 mm long/ 22.2 mm OD</li> </ul>
	WLK-0824-0973-00-0 450 mm long rod	<ul style="list-style-type: none"> <li>• rod 450 mm long/ 22.2 mm OD</li> <li>• standard accessory for the MANTIS Battery enables the counterweight to be fixed on any side</li> </ul>
	WLK-0633-22-02-00-0 500 mm long rod	<ul style="list-style-type: none"> <li>• rod 500 mm long/ 22.2 mm OD</li> <li>• optional accessory for the MANTIS Battery enables the counterweight to be fixed on any side</li> </ul>
	KST-0525-11-00-00-0 Double clamping block with levers	<ul style="list-style-type: none"> <li>• two holes 22.2 mm ID</li> </ul>
	TLJ-0419-04-02-03-0 Isolation tube for welding torch	<ul style="list-style-type: none"> <li>• insulation tube 22.2 mm OD/15 mm ID</li> </ul>

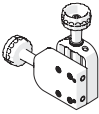
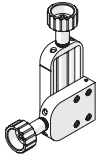
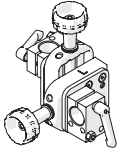
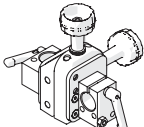
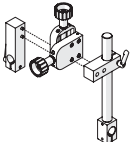
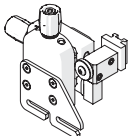
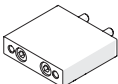
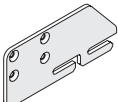
Product	Product Code / Description	Specification
	ZCS-0475-28-10-00-0 Standard torch holder incl. clamp 28-35 mm	<ul style="list-style-type: none"> <li>• clamp for cutting torches ranged 28-35 mm OD</li> <li>• dowel pin 22.2 mm OD</li> </ul>
	UCW-0475-28-00-00-0 Standard torch holder incl. clamp 28-35 mm and angle adjustment	<ul style="list-style-type: none"> <li>• clamp for cutting torches ranged 28-35 mm OD</li> <li>• dowel pin 22.2 mm OD</li> <li>• double clamping block with two holes 22.2 mm ID and levers</li> </ul>
	UCW-0753-08-00-00-0 Precise torch holder incl. clamp 28-35 mm with angle and height adjustment	<ul style="list-style-type: none"> <li>• clamp for cutting torches ranged 28-35 mm OD</li> <li>• dowel pin 22.2 mm OD</li> <li>• tilt the torch 45 degrees to the left and right</li> <li>• up-down adjustment within a range of up to 81 mm</li> <li>• double clamping block with tapered tip with two holes 22.2 mm ID and levers</li> </ul>
	UCW-0475-61-00-00-0 Machine torch holder 30 mm (1-3/16")	<ul style="list-style-type: none"> <li>• suitable for 30 mm (1-3/16") diameter barrel machine torch with 32 pitch rack</li> <li>• 32 pitch gear shaft</li> <li>• double clamping block with two holes 22.2 mm ID and levers</li> </ul>
	UCW-0475-29-00-00-1 Machine torch holder 35 mm (1-3/8")	<ul style="list-style-type: none"> <li>• suitable for 35 mm (1-3/8") diameter barrel machine torch with 32 pitch rack</li> <li>• 32 pitch gear shaft</li> <li>• double clamping block with two holes 22.2 mm ID and levers</li> </ul>
	UCW-0753-22-00-00-0 Precise machine torch holder 30 mm (1-3/16") with angle adjustment	<ul style="list-style-type: none"> <li>• suitable for 30 mm (1-3/16") diameter barrel machine torch with 32 pitch rack</li> <li>• 32 pitch gear shaft</li> <li>• tilt the torch 45 degrees to the left and right</li> <li>• double clamping block with tapered tip with two holes 22.2 mm ID and levers</li> </ul>
	UCW-0753-24-00-00-0 Precise machine torch holder 35 mm (1-3/8") with angle adjustment	<ul style="list-style-type: none"> <li>• suitable for 35 mm (1-3/8") diameter barrel machine torch with 32 pitch rack</li> <li>• 32 pitch gear shaft</li> <li>• tilt the torch 45 degrees to the left and right</li> <li>• double clamping block with tapered tip with two holes 22.2 mm ID and levers</li> </ul>

Product	Product Code / Description	Specification
	RAM-0523-17-00-00-0 300 mm long rod with 182 mm geared rack	<ul style="list-style-type: none"> <li>• 300 mm total length</li> <li>• 22.2 mm OD at the rod ends</li> <li>• 25 mm OD on a 182 mm long geared rack</li> </ul>
	RAM-0475-07-01-00-0 300 mm long rod with 241 mm geared rack	<ul style="list-style-type: none"> <li>• 300 mm total length</li> <li>• 22.2 mm OD at the rod ends</li> <li>• 25 mm OD on a 241 mm long geared rack</li> <li>• tapped hole M6 - 12 deep    14 total, at both ends</li> </ul>
	RAM-0753-07-00-00-0 540 mm long rod with 449 mm geared rack	<ul style="list-style-type: none"> <li>• 540 mm total length</li> <li>• 22.2 mm OD at the rod ends</li> <li>• 25 mm OD on a 449 mm long geared rack</li> <li>• tapped hole M6 - 12 deep    14 total, at both ends</li> </ul>
	RAM-0475-07-03-00-0 700 mm long rod with 647 mm geared rack	<ul style="list-style-type: none"> <li>• 700 mm total length</li> <li>• 22.2 mm OD at the rod ends</li> <li>• 25 mm OD on a 647 mm long geared rack</li> <li>• tapped hole M6 - 12 deep    14 total, at both ends</li> </ul>
	RAM-0753-13-00-00-0 1000 mm long rod with 940 mm geared rack	<ul style="list-style-type: none"> <li>• 1000 mm total length</li> <li>• 22.2 mm OD at the rod ends</li> <li>• 25 mm OD on a 940 mm long geared rack</li> <li>• tapped hole M6 - 12 deep    14 total, at both ends</li> </ul>
	ZSP-0475-62-00-00-0 Sliding clamping block type 1	<ul style="list-style-type: none"> <li>• hole 25 mm ID for moving rods with geared rack (in Z axis) up and down</li> <li>• star knob with sprocket m=1 t=16</li> <li>• hole 22.2 mm ID for rods</li> <li>• 2 locking levers</li> </ul>
	UCW-0475-15-00-00-1 Sliding clamping block type 2	<ul style="list-style-type: none"> <li>• hole 25 mm ID for moving rods with geared rack (in Y axis) left and right</li> <li>• star knob with sprocket m=1 t=16</li> <li>• hole 22.2 mm ID for rods</li> <li>• 2 locking levers</li> </ul>
	ZSP-0475-94-00-00-0 Double sliding clamping block	<ul style="list-style-type: none"> <li>• 2 holes 25 mm ID for moving rods with geared rack</li> <li>• 2 star knob with sprocket m=1 t=16</li> <li>• 2 locking levers</li> </ul>
	KST-0475-82-00-00-0 Clamping block (large)	<ul style="list-style-type: none"> <li>• hole 22.2 mm ID for rods</li> <li>• hole 25 mm ID for rods with geared rack</li> <li>• 2 locking levers</li> </ul>
	PDT-0475-26-00-00-0 Roller supporter	<ul style="list-style-type: none"> <li>• 280 mm long rod with roller ball</li> <li>• hole 22.2 mm ID for rod with roller ball</li> <li>• hole 25 mm ID for rod with geared rack</li> <li>• 2 locking levers</li> </ul>

Product	Product Code / Description	Specification	Product	Product Code / Description	Specification
	RZD-0475-64-00-00-0 Manifold 2x2 (metric)	<ul style="list-style-type: none"> <li>inlet 1/4" RH</li> <li>inlet 3/8" LH</li> <li>outlet 1/4" RH</li> <li>outlet 3/8" LH</li> </ul>		RZD-0475-68-00-00-0 Manifold 2x2 (imperial)	<ul style="list-style-type: none"> <li>inlet 9/16" RH</li> <li>inlet 9/16" LH</li> <li>outlet 9/16" RH</li> <li>outlet 9/16" LH</li> </ul>
	RZD-0475-65-00-00-0 Manifold 2x2 with cut-off valve (metric)	<ul style="list-style-type: none"> <li>inlet 1/4" RH</li> <li>inlet 3/8" LH</li> <li>outlet 1/4" RH</li> <li>outlet 3/8" LH</li> <li>cut-off valve</li> </ul>		RZD-0475-70-00-00-0 Manifold 2x2 with cut-off valve (imperial)	<ul style="list-style-type: none"> <li>inlet 9/16" RH</li> <li>inlet 9/16" LH</li> <li>outlet 9/16" RH</li> <li>outlet 9/16" LH</li> <li>cut-off valve</li> </ul>
	RZD-0475-63-00-00-0 Manifold 2x3 (metric)	<ul style="list-style-type: none"> <li>inlet 1/4" RH</li> <li>inlet 3/8" LH</li> <li>outlet 1/4" RH (2 pcs)</li> <li>outlet 3/8" LH</li> </ul>		RZD-0475-67-00-00-0 Manifold 2x3 (imperial)	<ul style="list-style-type: none"> <li>inlet 9/16" RH</li> <li>inlet 9/16" LH</li> <li>outlet 9/16" RH (2 pcs)</li> <li>outlet 9/16" LH</li> </ul>
	RZD-0475-66-00-00-0 Manifold 2x3 with cut-off valve (metric)	<ul style="list-style-type: none"> <li>inlet 1/4" RH</li> <li>inlet 3/8" LH</li> <li>outlet 1/4" RH (2 pcs)</li> <li>outlet 3/8" LH</li> <li>cut-off valve</li> </ul>		RZD-0475-69-00-00-0 Manifold 2x3 with cut-off valve (imperial)	<ul style="list-style-type: none"> <li>inlet 9/16" RH</li> <li>inlet 9/16" LH</li> <li>outlet 9/16" RH (2 pcs)</li> <li>outlet 9/16" LH</li> <li>cut-off valve</li> </ul>
	RZD-0475-74-00-00-0 Manifold 3/3 (metric)	<ul style="list-style-type: none"> <li>inlet 1/4" RH (2 pcs)</li> <li>inlet 3/8" LH</li> <li>outlet 1/4" RH (2 pcs)</li> <li>outlet 3/8" LH</li> </ul>		RZD-0475-73-00-00-0 Manifold 3/3 (imperial)	<ul style="list-style-type: none"> <li>inlet 9/16" RH (2 pcs)</li> <li>inlet 9/16" LH</li> <li>outlet 9/16" RH (2 pcs)</li> <li>outlet 9/16" LH</li> </ul>
	RZD-0475-72-00-00-0 Manifold 3/3 with cut-off valve (metric)	<ul style="list-style-type: none"> <li>inlet 1/4" RH (2 pcs)</li> <li>inlet 3/8" LH</li> <li>outlet 1/4" RH (2 pcs)</li> <li>outlet 3/8" LH</li> <li>cut-off valve</li> </ul>		RZD-0475-71-00-00-0 Manifold 3/3 with cut-off valve (imperial)	<ul style="list-style-type: none"> <li>inlet 9/16" RH (2 pcs)</li> <li>inlet 9/16" LH</li> <li>outlet 9/16" RH (2 pcs)</li> <li>outlet 9/16" LH</li> <li>cut-off valve</li> </ul>
	WSP-0525-12-00-00-0 Gas manifold bracket for RAIL BULL			PDT-0475-87-00-00-0 Gas manifold bracket for DRAGON family	


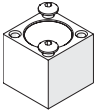
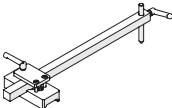
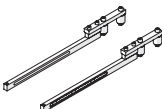
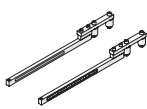
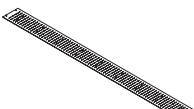
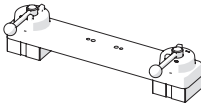
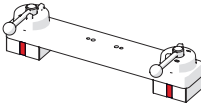
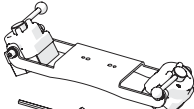
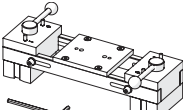
Product	Product Code / Description	Specification
	CYR-0475-22-00-00-0 Circle cutting attachment	<ul style="list-style-type: none"> <li>allows for cutting holes with the radius of 240-1000 mm (9 29/64"-39 3/8")</li> </ul>
	CYR-0475-83-00-00-0 Circle cutting attachment (extended)	<ul style="list-style-type: none"> <li>allows for cutting holes with the radius of 400-2500 mm (15 3/4"-98 27/64")</li> </ul>
	PWG-0753-09-00-00-0 Counterweight 1.3 kg (2.9 lbs)	<ul style="list-style-type: none"> <li>1.3 kg (2.9 lbs)</li> </ul>
	PWG-0753-12-00-00-0 Large counterweight 2,6 kg (5,7lbs)	<ul style="list-style-type: none"> <li>2,6 kg (5,7 lbs)</li> </ul>
	PWG-0833-05-00-00-0 Counterweight 1.3 kg (2.9 lbs) with screw	<ul style="list-style-type: none"> <li>1.3 kg (2.9 lbs)</li> <li>incl. screw M6 x 40</li> </ul>
	PWG-0833-06-00-00-0 Large counterweight 2,6 kg (5,7 lbs) with screw	<ul style="list-style-type: none"> <li>2,6 kg (5,7lbs)</li> <li>incl. screw M6 x 40</li> </ul>
Product	Product Code / Description	Specification
	ZSP-0475-58-00-00-0 Plasma arc ignition	<ul style="list-style-type: none"> <li>switch ON/OFF</li> <li>4-pin male socket</li> </ul>
	KBL-0475-58-05-00-0 Arc ignition cable for plasma	<ul style="list-style-type: none"> <li>length: 6.5 m (21 ft)</li> <li>4-pin female connector (inlet)</li> <li>2 wires with female connectors (outlet)</li> </ul>

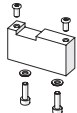
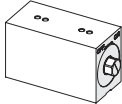
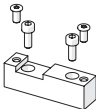
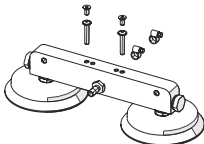
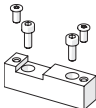
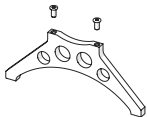
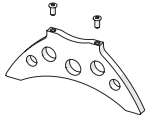
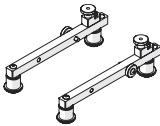

Product	Product Code / Description	Specification
	Batteries LiHD 18 V 4.0 Ah, 5.5 Ah, 10.0 Ah	<ul style="list-style-type: none"> <li>LiHD battery packs</li> <li>battery pack voltage: 18 V</li> <li>intelligent battery management for long-lasting battery packs</li> <li>too low and too high voltage</li> <li>too low and too high temperature</li> <li>failure of the temperature sensor</li> <li>internal battery failure</li> </ul>
	AKM-0738-10-00-01-0 Battery LiHD 18 V 4.0 Ah	<ul style="list-style-type: none"> <li>battery pack capacity: 4.0 Ah</li> <li>energy: 72 Wh</li> <li>weight: 580 g</li> </ul>
	AKM-0738-10-00-03-0 Battery LiHD 18 V 5.5 Ah	<ul style="list-style-type: none"> <li>battery pack capacity: 5.5 Ah</li> <li>energy: 99 Wh</li> <li>weight: 980 g</li> <li>suitable for DRAGON Battery only (requires mounting of optional shield OSL-0788-08-00-00-0)</li> </ul>
	AKM-0738-10-00-02-0 Battery LiHD 18 V 10.0 Ah	<ul style="list-style-type: none"> <li>battery pack capacity: 10.0 Ah</li> <li>energy: 180 Wh</li> <li>weight: 1010 g</li> <li>suitable for DRAGON Battery only (requires mounting of optional shield OSL-0788-08-00-00-0)</li> </ul>
	Quick Chargers ASC 145, "AIR COOLED"	<ul style="list-style-type: none"> <li>battery pack voltage: 12-36 V</li> <li>output rating: 145 W</li> <li>max. charging current: 8 A</li> <li>weight: 551 g</li> <li>the battery packs are charged up to 4x faster than with an entry level charger</li> <li>patented "AIR COOLED" charging technology for short charging times thanks to cooling the battery pack</li> <li>charging time: <ul style="list-style-type: none"> <li>~ 30 min (4.0 Ah)</li> <li>~ 41 min (5.5 Ah)</li> <li>~ 74 min (10.0 Ah)</li> </ul> </li> </ul>
	LDW-0738-10-00-30-0 Quick Charger ASC 145, "AIR COOLED"	<ul style="list-style-type: none"> <li>EU plug</li> </ul>
	LDW-0738-04-00-30-0 Quick Charger ASC 145, "AIR COOLED"	<ul style="list-style-type: none"> <li>UK plug</li> </ul>
	PWD-0466-18-00-00-0 Power cord 230 V (EU plug) 3 m	<ul style="list-style-type: none"> <li>length: 3 m (10 ft)</li> <li>EU plug</li> <li>suitable for RAIL TUG, RAIL TITAN 2</li> </ul>
	PWD-0466-28-00-00-0 Power cord 115 V (UK plug) 3 m	<ul style="list-style-type: none"> <li>length: 3 m (10 ft)</li> <li>UK plug</li> <li>suitable for RAIL TUG, RAIL TITAN 2</li> </ul>
	KBL-0466-17-00-00-0 Start-Stop arc ignition cable 6.5 m	<ul style="list-style-type: none"> <li>length: 6.5 m (21 ft)</li> <li>4-pin female connector (inlet)</li> <li>2 pairs of colour-coded wires with male and female connectors</li> <li>enables connection of 2 welders</li> </ul>
	KBL-0466-17-00-04-0 Start-Stop arc ignition cable 13 m	<ul style="list-style-type: none"> <li>length: 13 m (42 ft)</li> <li>4-pin female connector (inlet)</li> <li>2 pairs of colour-coded wires with male and female connectors</li> <li>enables connection of 2 welders</li> </ul>

Product	Product Code / Description	Specification
	ZSP-0466-14-00-00-0 Cross-slide 0-35 mm both up-down and left-right	<ul style="list-style-type: none"> <li>• 0-35 mm up and down adjustment</li> <li>• 0-35 mm left and right adjustment</li> </ul>
	ZSP-0466-46-00-00-1 Extended cross-slide 0-76 mm either up-down or left-right	<ul style="list-style-type: none"> <li>• 0-75 mm extended adjustment in the preferred axis</li> <li>• 0-35 mm adjustment in the second axis</li> <li>• the axis setting depends on the cross-slide mounting position</li> </ul>
	UKL-0824-1051-01-0 Cross slide assembly „Left”	<ul style="list-style-type: none"> <li>• 0-35 mm up and down adjustment</li> <li>• 0-35 mm left and right adjustment</li> <li>• suitable for torch adjustment as it is on the left</li> <li>• first-choice application: MANTIS Battery</li> </ul>
	UKL-0824-0974-01-0 Cross slide assembly „Right”	<ul style="list-style-type: none"> <li>• 0-35 mm up and down adjustment</li> <li>• 0-35 mm left and right adjustment</li> <li>• suitable for torch adjustment as it is on the right</li> <li>• first-choice application: MANTIS Battery</li> </ul>
	PRW-0482-11-00-00-0 Cross-slide assembly for RAIL BULL	<ul style="list-style-type: none"> <li>• 0-35 mm up and down adjustment</li> <li>• 0-35 mm left and right adjustment</li> <li>• first-choice application: RAIL BULL</li> </ul>
	ZSP-0759-07-00-00-0 Cross-slide with bracket	<ul style="list-style-type: none"> <li>• suitable for MINI SPIDER Battery only</li> </ul>
	DYS-0759-08-00-00-0 Bracket for opposite torch placement	<ul style="list-style-type: none"> <li>• length: 55 mm</li> <li>• width: 60 mm</li> <li>• suitable for MINI SPIDER Battery only</li> </ul>
	WSP-0759-12-01-00-0 Enlarged cross slide bracket	<ul style="list-style-type: none"> <li>• increases the space for the torch by 50 mm</li> <li>• suitable for MINI SPIDER Battery only</li> </ul>

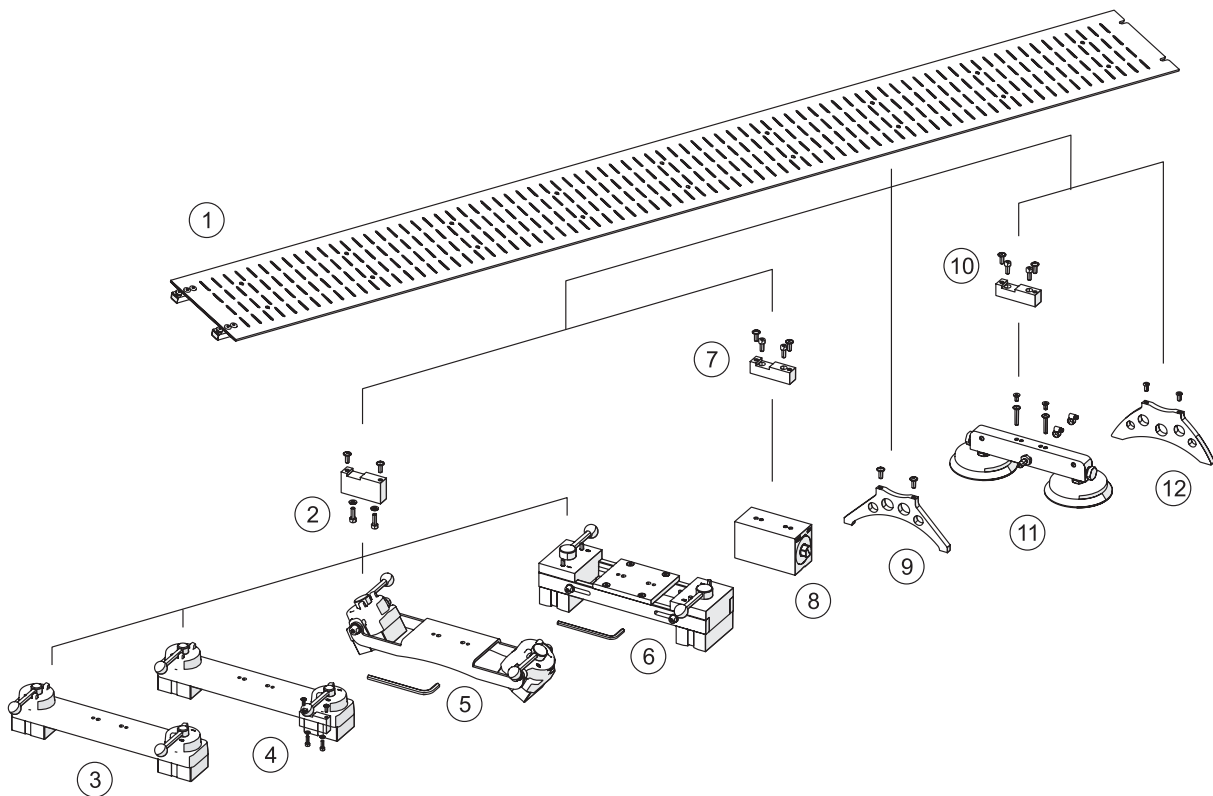
Product	Product Code / Description	Specification
	PDT-0526-21-00-00-0 Cable anchor for MINI SPIDER Battery	<ul style="list-style-type: none"> <li>• suitable for MINI SPIDER Battery only</li> <li>• rod length: 230 mm</li> <li>• rod diameter: 22.2 mm</li> </ul>
	PDT-0466-55-00-00-0 Cable anchor for GECKO and GECKO HS	<ul style="list-style-type: none"> <li>• suitable for GECKO/ GECKO HS only</li> <li>• rod length: 230 mm</li> <li>• rod diameter: 22.2 mm</li> </ul>
	PDT-0776-04-00-00-0 Cable anchor for GECKO Battery 2 and SCORPIO Battery	<ul style="list-style-type: none"> <li>• suitable for GECKO Battery 2 and SCORPIO Battery</li> <li>• rod length: 230 mm</li> <li>• rod diameter: 22.2 mm</li> </ul>
	PDT-0754-12-00-00-0 Cable anchor for LIZARD	<ul style="list-style-type: none"> <li>• suitable for LIZARD only</li> <li>• rod length: 230 mm</li> <li>• rod diameter: 22.2 mm</li> </ul>
	UCW-0466-55-03-00-0 Cable anchor for MANTIS Battery	<ul style="list-style-type: none"> <li>• suitable for MANTIS Battery</li> <li>• rod length: 230 mm</li> <li>• rod diameter: 22.2 mm</li> </ul>
	WSP-0760-06-00-00-0 Cable anchor for RAIL BULL	<ul style="list-style-type: none"> <li>• suitable for RAIL BULL only</li> </ul>
	UCW-0523-05-01-00-0 Cable anchor for RAIL TUG	<ul style="list-style-type: none"> <li>• suitable for RAIL TUG only</li> <li>• rod length: 110 mm</li> <li>• rod diameter: 22.2 mm</li> </ul>
	UCW-0654-02-00-00-0 Cable anchor for RAIL TITAN 2	<ul style="list-style-type: none"> <li>• suitable for RAIL TITAN 2 only</li> <li>• rod length: 220 mm</li> <li>• rod diameter: 22.2 mm</li> </ul>
	PDT-0475-34-00-00-0 Cable anchor for DRAGON family	<ul style="list-style-type: none"> <li>• suitable for DRAGON family only</li> <li>• rod length: 256 mm</li> <li>• rod diameter: 22.2 mm</li> </ul>

Product	Product Code / Description	Specification
	OSL-0466-29-00-00-0 Display cover for GECKO and GECKO HS	<ul style="list-style-type: none"> <li>• suitable for GECKO/ GECKO HS only</li> </ul>
	OSL-0526-22-00-00-0 Display cover for GECKO Battery 2	<ul style="list-style-type: none"> <li>• suitable for GECKO Battery 2 only</li> </ul>
	OSL-0476-23-00-00-0 Display cover for LIZARD	<ul style="list-style-type: none"> <li>• suitable for LIZARD only</li> </ul>
	OSL-0475-54-00-00-0 Heat protection shield (left)	<ul style="list-style-type: none"> <li>• suitable for DRAGON family only</li> </ul>
	OSL-0475-55-00-00-0 Heat protection shield (right)	<ul style="list-style-type: none"> <li>• suitable for DRAGON family only</li> </ul>
	OSL-0753-20-00-00-0 Heat protection shield (bottom)	<ul style="list-style-type: none"> <li>• suitable for DRAGON family only</li> </ul>
	OSL-0788-08-00-00-0 Enlarged battery shield	<ul style="list-style-type: none"> <li>• suitable for DRAGON Battery only</li> <li>• enables using LiHD CAS batteries: 5.5 Ah and 10.0 Ah</li> </ul>

Product	Product Code / Description	Specification
	PRW-0466-50-01-01-0 36 mm wide flexible track	<ul style="list-style-type: none"> <li>length: 1.85 m (6 ft)</li> <li>min. curvature radius: 1.0 m (3.3 ft)</li> <li>suitable for GECKO family, SCORPIO Battery, LIZARD</li> <li>requires magnetic blocks BLO-0466-68-00-00-0</li> </ul>
	BLO-0466-68-00-00-0 Magnetic block for 36 mm wide flexible track	<ul style="list-style-type: none"> <li>sold in bulk packaging of 10 pieces</li> </ul>
	UST-0466-53-00-00-0 Guide adjustment tool for 36 mm wide flexible track	<ul style="list-style-type: none"> <li>enables proper parallel alignment of 36 mm flexible track against an outside edge or groove</li> </ul>
	PRW-0752-14-00-00-1 Following guide arms 15 x 15 mm for 36 mm wide flexible track (set of 2 pcs)	<ul style="list-style-type: none"> <li>suitable for GECKO family, SCORPIO Battery</li> <li>cross-section: 15 mm x 15 mm</li> </ul>
	PRW-0476-50-01-00-1 Following guide arms 20 x 20 mm for 36 mm wide flexible track (set of 2 pcs)	<ul style="list-style-type: none"> <li>suitable for LIZARD</li> <li>cross-section: 20 mm x 20 mm</li> </ul>
	PRW-0466-71-00-00-0 160 mm wide flexible track	<ul style="list-style-type: none"> <li>length: 1.88 m (6.1 ft)</li> <li>min. curvature radius: 1.25 m (4.1 ft)</li> <li>suitable for GECKO family, SCORPIO Battery</li> <li>enables various configurations (see suitable accessories below)</li> </ul>
	ZSP-0475-92-00-00-0 Magnetic unit	<ul style="list-style-type: none"> <li>suitable for: 160 mm wide flexible track, hi-flex track, semi-flexible track, rigid track, V-track</li> <li>allows clamping tracks to ferromagnetic surfaces</li> <li>maximum holding force up to 2500 N</li> <li>intermediate position (between OFF/ON) with partial holding force helps to adjust the right track position</li> <li>requires bracket DYS-0466-71-05-00-0 for 160 mm wide flexible track</li> </ul>
	ZSP-0475-93-00-00-0 Heat-resistant magnetic unit	<ul style="list-style-type: none"> <li>suitable for: 160 mm wide flexible track, hi-flex track, semi-flexible track, rigid track, V-track</li> <li>suitable for working on more heated ferromagnetic surfaces</li> <li>maximum holding force up to 2500 N</li> <li>intermediate position (between OFF/ON) with partial holding force helps to adjust the right track position</li> <li>requires bracket DYS-0466-71-05-00-0 for 160 mm wide flexible track</li> </ul>
	ZSP-0475-85-00-00-0 Pivoting magnetic unit	<ul style="list-style-type: none"> <li>suitable for: 160 mm wide flexible track, hi-flex track, semi-flexible track, rigid track</li> <li>allows clamping tracks to flat, concave or convex ferromagnetic surfaces and pipes ID of at least 800 mm (31.5")</li> <li>may also be fixed on surfaces that differ in height up to 80 mm (3.1")</li> <li>maximum holding force up to 2500 N</li> <li>intermediate position (between OFF/ON) with partial holding force helps to adjust the right track position</li> <li>requires bracket DYS-0466-71-05-00-0 for 160 mm wide flexible track</li> </ul>
	ZSP-0523-19-00-00-0 Spacing-adjustable magnetic unit	<ul style="list-style-type: none"> <li>suitable for: 160 mm wide flexible track, hi-flex track, semi-flexible track, rigid track</li> <li>allows clamping tracks to ferromagnetic pipes with diameters of 25-230 mm (1-9") and the distance between pipe axes of 170-230 mm (6.7-9.1")</li> <li>maximum holding force up to 2500 N</li> <li>intermediate position (between OFF/ON) with partial holding force helps to adjust the right track position</li> <li>requires bracket DYS-0466-71-05-00-0 for 160 mm wide flexible track</li> </ul>

Product	Product Code / Description	Specification
	<p>DYS-0466-71-05-00-0 Bracket for magnetic units for 160 mm wide flexible track</p>	<ul style="list-style-type: none"> <li>• suitable for 160 mm wide flexible track only</li> <li>• enables mounting of magnetic unit, heat-resistant magnetic unit, pivoting magnetic unit, spacing-adjustable magnetic unit</li> </ul>
	<p>PDS-0582-10-00-02-0 Narrow magnetic unit with hexagon</p>	<ul style="list-style-type: none"> <li>• suitable for: 160 mm wide flexible track, hi-flex track, semi-flexible track, rigid track, V-track</li> <li>• allows clamping tracks to ferromagnetic surfaces and very close to their edges</li> <li>• maximum holding force up to 1500 N</li> <li>• intermediate position (between OFF/ON) with partial holding force helps to adjust the right track position</li> <li>• requires bracket <b>DYS-0466-71-07-00-0</b> for 160 mm wide flexible track</li> </ul>
	<p>DYS-0466-71-07-00-0 Bracket for narrow magnetic unit for 160 mm wide flexible track</p>	<ul style="list-style-type: none"> <li>• suitable for 160 mm wide flexible track only</li> <li>• enables mounting of narrow magnetic unit</li> </ul>
	<p>MST-0541-10-02-00-0 Vacuum modular unit</p>	<ul style="list-style-type: none"> <li>• suitable for: 160 mm wide flexible track, hi-flex track, semi-flexible track, rigid track, V-track</li> <li>• allows clamping tracks on both non-ferrous and ferromagnetic materials</li> <li>• maximum holding force up to 1400 N</li> <li>• consists of 2 vacuum pads and manifold block</li> <li>• depending on purpose-built configurations can function as entry, middle, extension or end vacuum unit (see Vacuum System at page 30)</li> <li>• requires bracket <b>DYS-0466-71-04-00-0</b> for 160 mm wide flexible track</li> </ul>
	<p>DYS-0466-71-04-00-0 Bracket for vacuum modular unit for 160 mm wide flexible track</p>	<ul style="list-style-type: none"> <li>• suitable for 160 mm wide flexible track only</li> <li>• enables mounting of vacuum modular unit</li> </ul>
	<p>WSP-0466-71-06-00-0 Steel support for 160 mm wide flexible track</p>	<ul style="list-style-type: none"> <li>• suitable only for 160 mm wide flexible track when equipped with magnetic units</li> </ul>
	<p>WSP-0466-71-03-00-0 Aluminium support for 160 mm wide flexible track</p>	<ul style="list-style-type: none"> <li>• suitable only for 160 mm wide flexible track when equipped with vacuum modular units</li> </ul>
	<p>ZST-0466-69-00-00-0 Following guide arms for 160 mm wide flexible track (set of 2 pcs)</p>	<ul style="list-style-type: none"> <li>• suitable for GECKO family, SCORPIO Battery</li> </ul>
	<p>URZ-000001 Fall arrester device</p>	<ul style="list-style-type: none"> <li>• secures a track against falling</li> </ul>

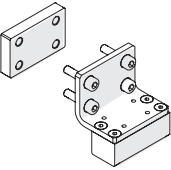
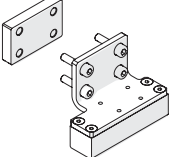
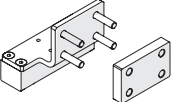
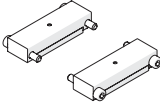




160 MM WIDE FLEXIBLE TRACK




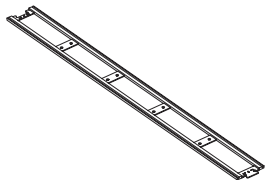
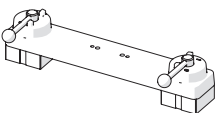
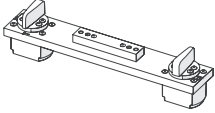


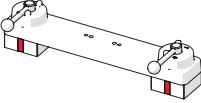
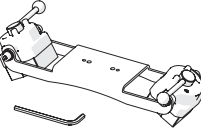
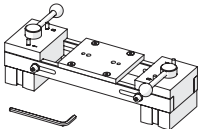
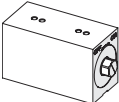
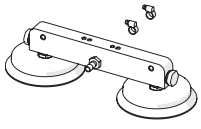
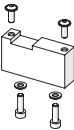
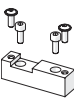
Ref.	Product code	Description
1	PRW-0466-71-00-00-0	160 mm wide flexible track length 1.88 m (6.1 ft), minimum curvature radius of 1.25 m (4.1 ft)
2	DYS-0466-71-05-00-0	Bracket for magnetic units for 160 mm wide flexible track
3	ZSP-0475-92-00-00-0	Magnetic unit
4	ZSP-0475-93-00-00-0	Heat-resistant magnetic unit
5	ZSP-0475-85-00-00-0	Pivoting magnetic unit
6	ZSP-0523-19-00-00-0	Spacing-adjustable magnetic unit
7	DYS-0466-71-07-00-0	Bracket for narrow magnetic unit for 160 mm wide flexible track
8	PDS-0582-10-00-02-0	Narrow magnetic unit with hexagon
9	WSP-0466-71-06-00-0	Steel support for 160 mm wide flexible track
10	DYS-0466-71-04-00-0	Bracket for vacuum modular unit for 160 mm wide flexible track
11	MST-0541-10-02-00-0	Vacuum modular unit
12	WSP-0466-71-03-00-0	Aluminium support for 160 mm wide flexible track

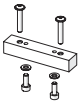

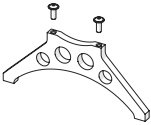
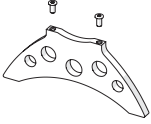
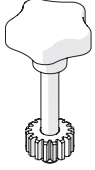
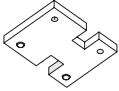
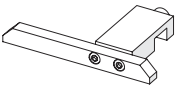
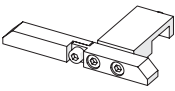

Product	Product Code / Description	Specification
	ZST-0752-17-00-00-1 Standard guide arms 15 x 15 mm (set of 2 pcs)	<ul style="list-style-type: none"> <li>• suitable for GECKO family, SCORPIO Battery</li> <li>• cross-section: 15 mm x 15 mm</li> </ul>
	PRW-0466-41-00-00-1 Edge following guide arms 15 x 15 mm (set of 2 pcs)	<ul style="list-style-type: none"> <li>• suitable for GECKO family</li> <li>• cross-section: 15 mm x 15 mm</li> </ul>
	PRW-0752-10-00-00-1 Adjustable guide arms 15 x 15 mm (set of 2 pcs)	<ul style="list-style-type: none"> <li>• suitable for GECKO family, SCORPIO Battery</li> <li>• cross-section: 15 mm x 15 mm</li> </ul>
	PRW-0752-11-00-00-1 Magnet guide arms 15 x 15 mm (set of 2 pcs)	<ul style="list-style-type: none"> <li>• suitable for GECKO family, SCORPIO Battery</li> <li>• cross-section: 15 mm x 15 mm</li> </ul>
	PRW-0752-12-00-00-1 Low guide arms 15 x 15 mm (set of 2 pcs)	<ul style="list-style-type: none"> <li>• suitable for GECKO family, SCORPIO Battery</li> <li>• cross-section: 15 mm x 15 mm</li> </ul>
	PRW-0752-13-00-00-1 High guide arms 15 x 15 mm (set of 2 pcs)	<ul style="list-style-type: none"> <li>• suitable for GECKO family, SCORPIO Battery</li> <li>• cross-section: 15 mm x 15 mm</li> </ul>
	PRW-0752-14-00-00-1 Following guide arms 15 x 15 mm for 36 mm wide flexible track (set of 2 pcs)	<ul style="list-style-type: none"> <li>• suitable for GECKO family, SCORPIO Battery</li> <li>• cross-section: 15 mm x 15 mm</li> </ul>
	SRB-0466-10-00-00-0 Guide arm screw short 30 mm	<ul style="list-style-type: none"> <li>• suitable for GECKO family, SCORPIO Battery</li> <li>• length: 30 mm</li> <li>• knurled nut</li> <li>• for guide arms with cross-section 15 mm x 15 mm</li> </ul>

Product	Product Code / Description	Specification
	PRW-0476-56-00-00-0 Standard guide arms 20 x 20 mm (set of 2 pcs)	<ul style="list-style-type: none"> <li>• only for LIZARD</li> <li>• cross-section: 20 mm x 20 mm</li> </ul>
	PRW-0476-21-00-00-1 Edge following guide arms 20 x 20 mm (set of 2 pcs)	<ul style="list-style-type: none"> <li>• only for LIZARD</li> <li>• cross-section: 20 mm x 20 mm</li> </ul>
	PRW-0476-22-00-00-1 Adjustable guide arms 20 x 20 mm (set of 2 pcs)	<ul style="list-style-type: none"> <li>• only for LIZARD</li> <li>• cross-section: 20 mm x 20 mm</li> </ul>
	PRW-0476-52-00-00-1 Magnet guide arms 20 x 20 mm (set of 2 pcs)	<ul style="list-style-type: none"> <li>• only for LIZARD</li> <li>• cross-section: 20 mm x 20 mm</li> </ul>
	PRW-0476-54-00-00-1 Low guide arms 20 x 20 mm (set of 2 pcs)	<ul style="list-style-type: none"> <li>• only for LIZARD</li> <li>• cross-section: 20 mm x 20 mm</li> </ul>
	PRW-0476-55-00-00-1 High guide arms 20 x 20 mm (set of 2 pcs)	<ul style="list-style-type: none"> <li>• only for LIZARD</li> <li>• cross-section: 20 mm x 20 mm</li> </ul>
	PRW-0476-50-01-00-1 Following guide arms 20 x 20 mm for 36 mm wide flexible track (set of 2 pcs)	<ul style="list-style-type: none"> <li>• only for LIZARD</li> <li>• cross-section: 20 mm x 20 mm</li> </ul>
	SRB-0476-08-00-00-0 Guide arm screw long 40 mm	<ul style="list-style-type: none"> <li>• only for LIZARD</li> <li>• length: 40 mm</li> <li>• knurled nut</li> <li>• for guide arms with cross-section 20 mm x 20 mm</li> </ul>

Product	Product Code / Description	Specification
	BLO-0466-45-01-00-0 Magnet blocks (front & back) clamping force 55 N	<ul style="list-style-type: none"> <li>• suitable for GECKO/ GECKO HS and GECKO Battery 2</li> <li>• clamping force: 55 N</li> <li>• enables mounting on both sides of the tractor</li> </ul>
	BLO-0752-22-00-00-0 Magnet blocks (front) clamping force 80 N	<ul style="list-style-type: none"> <li>• suitable for GECKO/ GECKO HS and GECKO Battery 2</li> <li>• clamping force: 80 N</li> <li>• for mounting at the front</li> </ul>
	BLO-0466-48-01-00-0 Magnet blocks (back) clamping force 80 N	<ul style="list-style-type: none"> <li>• suitable for GECKO/ GECKO HS and GECKO Battery 2</li> <li>• clamping force: 80 N</li> <li>• for mounting at the back</li> </ul>
	ZSP-0759-10-00-00-0 Auxiliary magnet blocks	<ul style="list-style-type: none"> <li>• for MINI SPIDER Battery only</li> </ul>
Product	Product Code / Description	Specification
	KOL-0752-01-04-00-0 Standard drive wheel for GECKO family and SCORPIO Battery	<ul style="list-style-type: none"> <li>• suitable for GECKO family, SCORPIO Battery</li> <li>• diameter: 60 mm</li> <li>• increased heat-resistant silicone coating</li> </ul>
	KOL-0466-72-00-00-0 Stainless steel drive wheel for GECKO family and SCORPIO Battery	<ul style="list-style-type: none"> <li>• suitable for GECKO family, SCORPIO Battery</li> <li>• diameter: 60 mm</li> <li>• made of stainless steel</li> </ul>
	KOL-0754-01-10-00-0 Standard drive wheel for LIZARD	<ul style="list-style-type: none"> <li>• suitable for LIZARD</li> <li>• diameter: 75 mm</li> <li>• increased heat-resistant silicone coating</li> </ul>
	KOL-0476-57-00-00-0 Stainless steel drive wheel for LIZARD	<ul style="list-style-type: none"> <li>• suitable for LIZARD</li> <li>• diameter: 75 mm</li> <li>• made of stainless steel</li> </ul>

Product	Product Code / Description	Specification
	<p>TRO-0673-00-00-00-0 Hi-flex track</p>	<ul style="list-style-type: none"> <li>• suitable for RAIL TUG and RAIL TITAN 2</li> <li>• for circumferential, irregular and straight line applications</li> <li>• minimum curve radius on convex surface is 0.75 m (30")</li> <li>• minimum curve radius on concave surface is 1.7 m (67")</li> <li>• minimum OD 1.5 m (60") for external run</li> <li>• length of a single rail 1.52 m (5 ft)</li> <li>• the maximum number of units is 15 pcs (if narrow magnetic units are in use)</li> <li>• joinable for unlimited run length</li> <li>• can be fixed on both ferrous and non-ferrous materials by means of magnetic or vacuum units to allow travel in any plane or position</li> <li>• enables various configurations (see suitable accessories below)</li> </ul>
	<p>PRW-0482-15-05-00-0 Semi-flexible track</p>	<ul style="list-style-type: none"> <li>• suitable for RAIL BULL, RAIL TUG and RAIL TITAN 2</li> <li>• for circumferential, irregular and straight line applications</li> <li>• minimum radius of 5.0 m (16.4 ft) or 10.0 m (32.8 ft) diameter without permanent deformation</li> <li>• length of a single rail 2 m (6.5 ft)</li> <li>• joinable for unlimited run length</li> <li>• can be fixed on both ferrous and non-ferrous materials by means of magnetic or vacuum units to allow travel in any plane or position</li> <li>• enables various configurations (see suitable accessories below)</li> </ul>
	<p>PRW-0482-47-00-00-0 Rigid track</p>	<ul style="list-style-type: none"> <li>• suitable for RAIL BULL, RAIL TUG and RAIL TITAN 2</li> <li>• for straight line applications incl. out of workpiece position</li> <li>• length of a single rail 2 m (6.5 ft)</li> <li>• cannot be bent at all</li> <li>• joinable for unlimited run length</li> <li>• can be fixed on both ferrous and non-ferrous materials by means of magnetic or vacuum units to allow travel in any plane or position</li> <li>• enables various configurations (see suitable accessories below)</li> </ul>
	<p>TRO-0475-13-00-00-0 V-track</p>	<ul style="list-style-type: none"> <li>• suitable for DRAGON family</li> <li>• for straight line applications</li> <li>• "V" Groove center line 152 mm (6")</li> <li>• length of a single rail 1.8 m (5.9 ft)</li> <li>• joinable for unlimited run length</li> <li>• can be fixed on both ferrous and non-ferrous materials by means of magnetic or vacuum units</li> <li>• enables various configurations (see suitable accessories below)</li> </ul>
	<p>ZSP-0475-92-00-00-0 Magnetic unit</p>	<ul style="list-style-type: none"> <li>• suitable for: 160 mm wide flexible track, hi-flex track, semi-flexible track, rigid track, V-track</li> <li>• allows clamping tracks to ferromagnetic surfaces</li> <li>• maximum holding force up to 2500 N</li> <li>• intermediate position (between OFF/ON) with partial holding force helps to adjust the right track position</li> <li>• requires bracket DYS-0482-19-00-00-0 for hi-flex track and semi-flexible track</li> <li>• requires bracket DYS-0482-21-00-00-0 for rigid track</li> <li>• requires bracket DYS-0466-71-05-00-0 for 160 mm wide flexible track</li> </ul>
	<p>MST-0677-00-00-00-0 Lightweight magnetic unit</p>	<ul style="list-style-type: none"> <li>• suitable for: rigid track, V-track</li> <li>• allows clamping tracks to ferromagnetic surfaces in horizontal position</li> <li>• lower weight (1.3 kg vs 2.7 kg) and smaller dimensions comparing to regular magnetic unit</li> <li>• maximum holding force up to 980 N</li> <li>• intermediate position (between OFF/ON) with partial holding force helps to adjust the right track position</li> <li>• requires bracket DYS-0482-21-00-00-0 for rigid track</li> </ul>

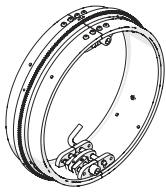
Product	Product Code / Description	Specification
	<p>ZSP-0475-93-00-00-0 Heat-resistant magnetic unit</p>	<ul style="list-style-type: none"> <li>• suitable for: 160 mm wide flexible track, hi-flex track, semi-flexible track, rigid track, V-track</li> <li>• suitable for working on more heated ferromagnetic surfaces</li> <li>• maximum holding force up to 2500 N</li> <li>• intermediate position (between OFF/ON) with partial holding force helps to adjust the right track position</li> <li>• requires bracket DYS-0482-19-00-00-0 for hi-flex track and semi-flexible track</li> <li>• requires bracket DYS-0482-21-00-00-0 for rigid track</li> <li>• requires bracket DYS-0466-71-05-00-0 for 160 mm wide flexible track</li> </ul>
	<p>ZSP-0475-85-00-00-0 Pivoting magnetic unit</p>	<ul style="list-style-type: none"> <li>• suitable for: 160 mm wide flexible track, hi-flex track, semi-flexible track, rigid track</li> <li>• allows clamping tracks to flat, concave or convex ferromagnetic surfaces and pipes ID of at least 800 mm (31.5")</li> <li>• may also be fixed on surfaces that differ in height up to 80 mm (3.1")</li> <li>• maximum holding force up to 2500 N</li> <li>• intermediate position (between OFF/ON) with partial holding force helps to adjust the right track position</li> <li>• requires bracket DYS-0482-19-00-00-0 for hi-flex track and semi-flexible track</li> <li>• requires bracket DYS-0482-21-00-00-0 for rigid track</li> <li>• requires bracket DYS-0466-71-05-00-0 for 160 mm wide flexible track</li> </ul>
	<p>ZSP-0523-19-00-00-0 Spacing-adjustable magnetic unit</p>	<ul style="list-style-type: none"> <li>• suitable for: 160 mm wide flexible track, hi-flex track, semi-flexible track, rigid track</li> <li>• allows clamping tracks to ferromagnetic pipes with diameters of 25–230 mm (1–9") and the distance between pipe axes of 170–230 mm (6.7–9.1")</li> <li>• maximum holding force up to 2500 N</li> <li>• intermediate position (between OFF/ON) with partial holding force helps to adjust the right track position</li> <li>• requires bracket DYS-0482-19-00-00-0 for hi-flex track and semi-flexible track</li> <li>• requires bracket DYS-0482-21-00-00-0 for rigid track</li> <li>• requires bracket DYS-0466-71-05-00-0 for 160 mm wide flexible track</li> </ul>
	<p>PDS-0582-10-00-02-0 Narrow magnetic unit with hexagon</p>	<ul style="list-style-type: none"> <li>• suitable for: 160 mm wide flexible track, hi-flex track, semi-flexible track, rigid track, V-track</li> <li>• allows clamping tracks to ferromagnetic surfaces and very close to their edges</li> <li>• maximum holding force up to 1500 N</li> <li>• intermediate position (between OFF/ON) with partial holding force helps to adjust the right track position</li> <li>• requires bracket DYS-0582-10-00-00-0 for hi-flex track and semi-flexible track</li> <li>• requires bracket DYS-0466-71-07-00-0 for 160 mm wide flexible track</li> </ul>
	<p>MST-0541-10-02-00-0 Vacuum modular unit</p>	<ul style="list-style-type: none"> <li>• suitable for: 160 mm wide flexible track, hi-flex track, semi-flexible track, rigid track, V-track</li> <li>• allows clamping tracks on both non-ferrous and ferromagnetic materials</li> <li>• maximum holding force up to 1400 N</li> <li>• consists of 2 vacuum pads and manifold block</li> <li>• requires bracket DYS-0541-11-01-00-0 for hi-flex track and semi-flexible track</li> <li>• requires bracket DYS-0466-71-04-00-0 for 160 mm wide flexible track</li> <li>• depending on purpose-built configurations can function as entry, middle, extension or end vacuum unit (see Vacuum System at pages 30-31)</li> </ul>
	<p>DYS-0482-19-00-00-0 Bracket for magnetic units for hi-flex track and semi-flexible track</p>	<ul style="list-style-type: none"> <li>• suitable for hi-flex track and semi-flexible track</li> <li>• enables mounting of magnetic unit, heat-resistant magnetic unit, pivoting magnetic unit, spacing-adjustable magnetic unit</li> </ul>
	<p>DYS-0582-10-00-00-0 Bracket for narrow magnetic unit for hi-flex track and semi-flexible track</p>	<ul style="list-style-type: none"> <li>• suitable for hi-flex track and semi-flexible track</li> <li>• enables mounting of narrow magnetic unit</li> </ul>

Product	Product Code / Description	Specification
	<p>DYS-0482-21-00-00-0 Bracket for magnetic units for rigid track</p>	<ul style="list-style-type: none"> <li>• suitable for rigid track only</li> <li>• enables mounting of magnetic unit, heat-resistant magnetic unit, lightweight magnetic unit, pivoting magnetic unit, spacing-adjustable magnetic unit</li> </ul>
	<p>DYS-0541-11-01-00-0 Bracket for vacuum modular unit for hi-flex track and semi-flexible track</p>	<ul style="list-style-type: none"> <li>• suitable for hi-flex track and semi-flexible track</li> <li>• enables mounting of vacuum modular unit</li> </ul>
	<p>WSP-0523-12-01-00-1 Steel support for semi-flexible track</p>	<ul style="list-style-type: none"> <li>• suitable for semi-flexible track</li> </ul>
	<p>WSP-0541-11-02-00-0 Aluminum support for semi-flexible track</p>	<ul style="list-style-type: none"> <li>• suitable for semi-flexible track</li> </ul>
	<p>PKT-0341-13-00-00-0 Gear rack adjustment tool</p>	<ul style="list-style-type: none"> <li>• suitable for semi-flexible track and rigid track</li> <li>• eliminates the clearance between gear racks</li> </ul>
	<p>PLY-0341-12-03-00-0 Connecting plate for semi-flexible track</p>	<ul style="list-style-type: none"> <li>• suitable for semi-flexible track</li> </ul>
	<p>ZDR-0523-76-00-00-0 Contact block for semi-flexible and rigid tracks</p>	<ul style="list-style-type: none"> <li>• for adjusting the movement range of the RAIL TITAN 2</li> <li>• protects the RAIL TITAN 2 from falling out of the track with open ends</li> <li>• enables the activation of the RAIL TITAN 2 limit switch</li> <li>• suitable for semi-flexible track and rigid track</li> </ul>
	<p>ZDR-0673-08-00-00-0 Contact block for hi-flex track</p>	<ul style="list-style-type: none"> <li>• for adjusting the movement range of the RAIL TITAN 2</li> <li>• protects the RAIL TITAN 2 from falling out of the track with open ends</li> <li>• enables the activation of the RAIL TITAN 2 limit switch</li> <li>• suitable for hi-flex track</li> </ul>
	<p>ZSP-0673-07-00-00-0 Hi-flex track guiding rollers (set of 4 pcs)</p>	<ul style="list-style-type: none"> <li>• suitable for RAIL TUG and RAIL TITAN 2 to move on hi-flex track</li> </ul>

RING TRACKS

Product

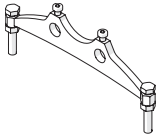
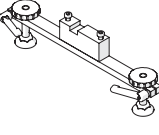
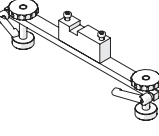
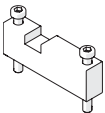
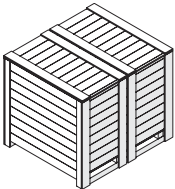
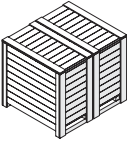
Specification



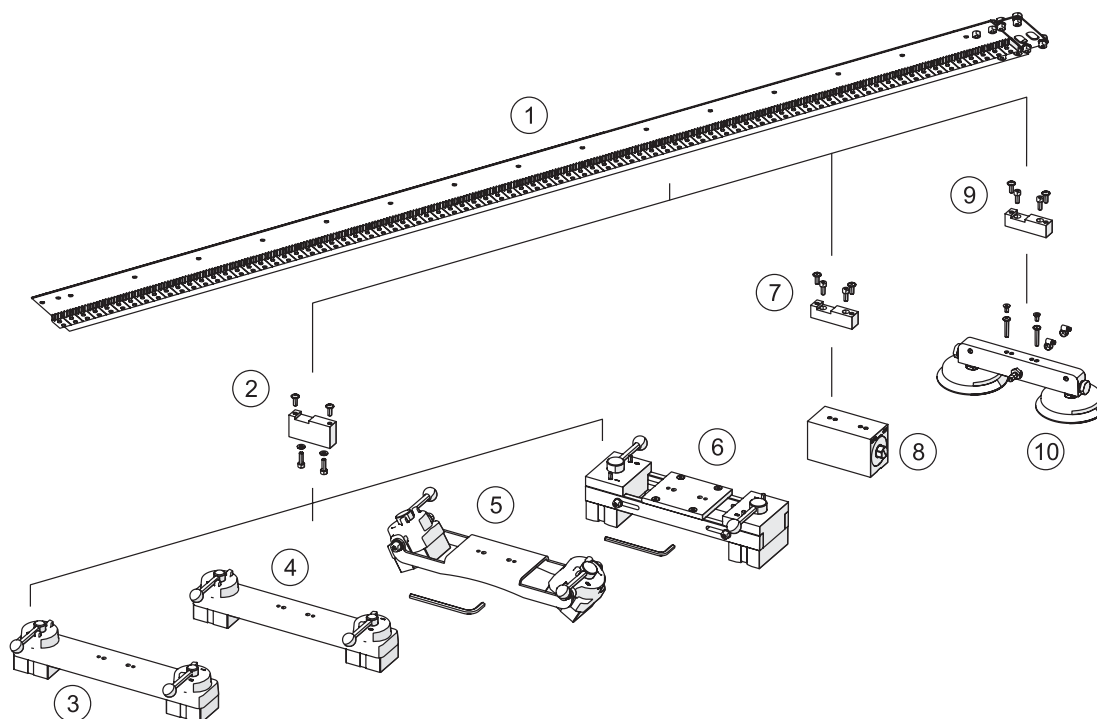
- for circumferential applications from 200 mm OD up to 3000 mm OD (from 8" to 10 ft)
- consists of either two, three or four segments depending on the workpiece diameter
- nominal OD diameter can be adjusted upwards by 50 mm
- nominal OD diameter can be adjusted downward by 50 mm by means of optional bracket for ring track supports
- can be fixed on both ferrous and non-ferrous materials by means of 3 types of supports
- suitable for RAIL TUG and RAIL TITAN 2

Product Code	Description	Ring segments	Ring track supports required	Product Code	Description	Ring segments	Ring track supports required
TRO-0523-14-00-00-0	Ring track OD 200-250 mm	2	4	TRO-0523-48-00-00-0	Ring track OD 1650-1700 mm	3	12
TRO-0523-78-00-00-0	Ring track OD 250-300 mm	2	4	TRO-0523-49-00-00-0	Ring track OD 1700-1750 mm	3	12
TRO-0523-20-00-00-0	Ring track OD 300-350 mm	2	4	TRO-0523-50-00-00-0	Ring track OD 1750-1800 mm	3	12
TRO-0523-21-00-00-0	Ring track OD 350-400 mm	2	4	TRO-0523-51-00-00-0	Ring track OD 1800-1850 mm	3	12
TRO-0523-23-00-00-0	Ring track OD 400-450 mm	2	6	TRO-0523-52-00-00-0	Ring track OD 1850-1900 mm	3	15
TRO-0523-24-00-00-0	Ring track OD 450-500 mm	2	6	TRO-0523-53-00-00-0	Ring track OD 1900-1950 mm	3	15
TRO-0523-25-00-00-0	Ring track OD 500-550 mm	2	6	TRO-0523-54-00-00-0	Ring track OD 1950-2000 mm	3	15
TRO-0523-26-00-00-0	Ring track OD 550-600 mm	2	6	TRO-0523-55-00-00-0	Ring track OD 2000-2050 mm	3	15
TRO-0523-22-00-00-0	Ring track OD 600-650 mm	2	6	TRO-0523-56-00-00-0	Ring track OD 2050-2100 mm	4	16
TRO-0523-28-00-00-0	Ring track OD 650-700 mm	2	6	TRO-0523-57-00-00-0	Ring track OD 2100-2150 mm	4	16
TRO-0523-29-00-00-0	Ring track OD 700-750 mm	2	6	TRO-0523-58-00-00-0	Ring track OD 2150-2200 mm	4	16
TRO-0523-30-00-00-0	Ring track OD 750-800 mm	2	6	TRO-0523-59-00-00-0	Ring track OD 2200-2250 mm	4	16
TRO-0523-31-00-00-0	Ring track OD 800-850 mm	2	6	TRO-0523-60-00-00-0	Ring track OD 2250-2300 mm	4	20
TRO-0523-32-00-00-0	Ring track OD 850-900 mm	2	6	TRO-0523-61-00-00-0	Ring track OD 2300-2350 mm	4	20
TRO-0523-33-00-00-0	Ring track OD 900-950 mm	2	8	TRO-0523-62-00-00-0	Ring track OD 2350-2400 mm	4	20
TRO-0523-34-00-00-0	Ring track OD 950-1000 mm	2	8	TRO-0523-63-00-00-0	Ring track OD 2400-2450 mm	4	20
TRO-0523-35-00-00-0	Ring track OD 1000-1050 mm	2	8	TRO-0523-64-00-00-0	Ring track OD 2450-2500 mm	4	20
TRO-0523-36-00-00-0	Ring track OD 1050-1100 mm	3	9	TRO-0523-65-00-00-0	Ring track OD 2500-2550 mm	4	20
TRO-0523-37-00-00-0	Ring track OD 1100-1150 mm	3	9	TRO-0523-66-00-00-0	Ring track OD 2550-2600 mm	4	20
TRO-0523-38-00-00-0	Ring track OD 1150-1200 mm	3	9	TRO-0523-67-00-00-0	Ring track OD 2600-2650 mm	4	20
TRO-0523-39-00-00-0	Ring track OD 1200-1250 mm	3	9	TRO-0523-68-00-00-0	Ring track OD 2650-2700 mm	4	20
TRO-0523-40-00-00-0	Ring track OD 1250-1300 mm	3	9	TRO-0523-69-00-00-0	Ring track OD 2700-2750 mm	4	20
TRO-0523-41-00-00-0	Ring track OD 1300-1350 mm	3	12	TRO-0523-70-00-00-0	Ring track OD 2750-2800 mm	4	20
TRO-0523-42-00-00-0	Ring track OD 1350-1400 mm	3	12	TRO-0523-71-00-00-0	Ring track OD 2800-2850 mm	4	20
TRO-0523-43-00-00-0	Ring track OD 1400-1450 mm	3	12	TRO-0523-72-00-00-0	Ring track OD 2850-2900 mm	4	20
TRO-0523-44-00-00-0	Ring track OD 1450-1500 mm	3	12	TRO-0523-73-00-00-0	Ring track OD 2900-2950 mm	4	20
TRO-0523-45-00-00-0	Ring track OD 1500-1550 mm	3	12	TRO-0523-74-00-00-0	Ring track OD 2950-3000 mm	4	20
TRO-0523-46-00-00-0	Ring track OD 1550-1600 mm	3	12	TRO-0523-75-00-00-0	Ring track OD 3000-3050 mm	4	20
TRO-0523-47-00-00-0	Ring track OD 1600-1650 mm	3	12				

## RING TRACKS

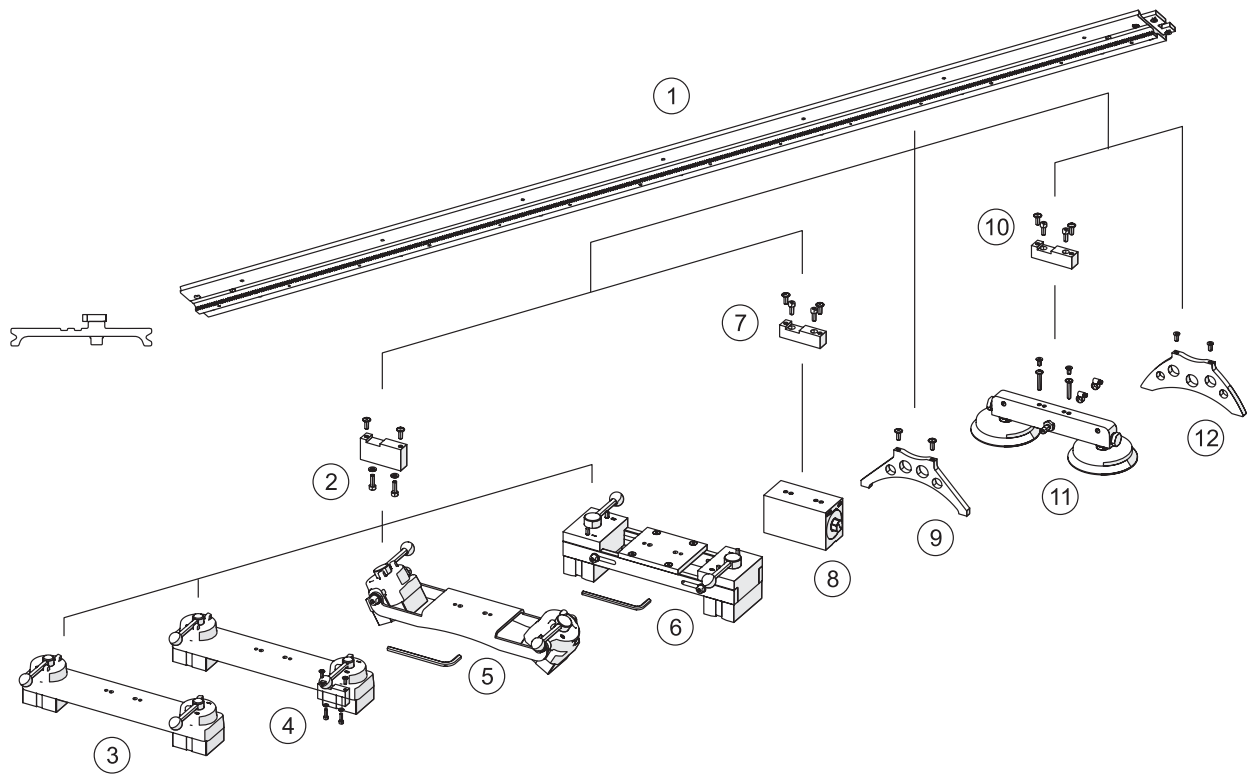
Product	Product Code / Description	Specification
	WSP-0654-11-00-00-0 Ring track support with bolts	
	WSP-0654-12-00-00-0 Ring track support with plastic feet	
	WSP-0654-13-00-00-0 Ring track support with magnets	
	DYS-0523-14-14-00-0 Bracket for ring track supports	<ul style="list-style-type: none"> <li>expands pipe diameter range by 50 mm downwards</li> </ul>
	SKR-0523-75-04-00-0 Big wooden box for ring tracks	<ul style="list-style-type: none"> <li>2360 x 880 x 360 mm</li> </ul>
	SKR-0523-75-05-00-0 Small wooden box for ring tracks	<ul style="list-style-type: none"> <li>1560 x 880 x 360 mm</li> </ul>

HI-FLEX TRACK



Ref.	Product code	Description
1	TR0-0673-00-00-00-0	Hi-Flex track length 1.52 m, min. OD 1500 mm
2	DYS-0482-19-00-00-0	Bracket for magnetic units for hi-flex track and semi-flexible track
3	ZSP-0475-92-00-00-0	Magnetic unit
4	ZSP-0475-93-00-00-0	Heat-resistant magnetic unit
5	ZSP-0475-85-00-00-0	Pivoting magnetic unit
6	ZSP-0523-19-00-00-0	Spacing-adjustable magnetic unit
7	DYS-0582-10-00-00-0	Bracket for narrow magnetic unit for hi-flex track and semi-flexible track
8	PDS-0582-10-00-02-0	Narrow magnetic unit with hexagon
9	DYS-0541-11-01-00-0	Bracket for vacuum modular unit for hi-flex track and semi-flexible track
10	MST-0541-10-02-00-0	Vacuum modular unit

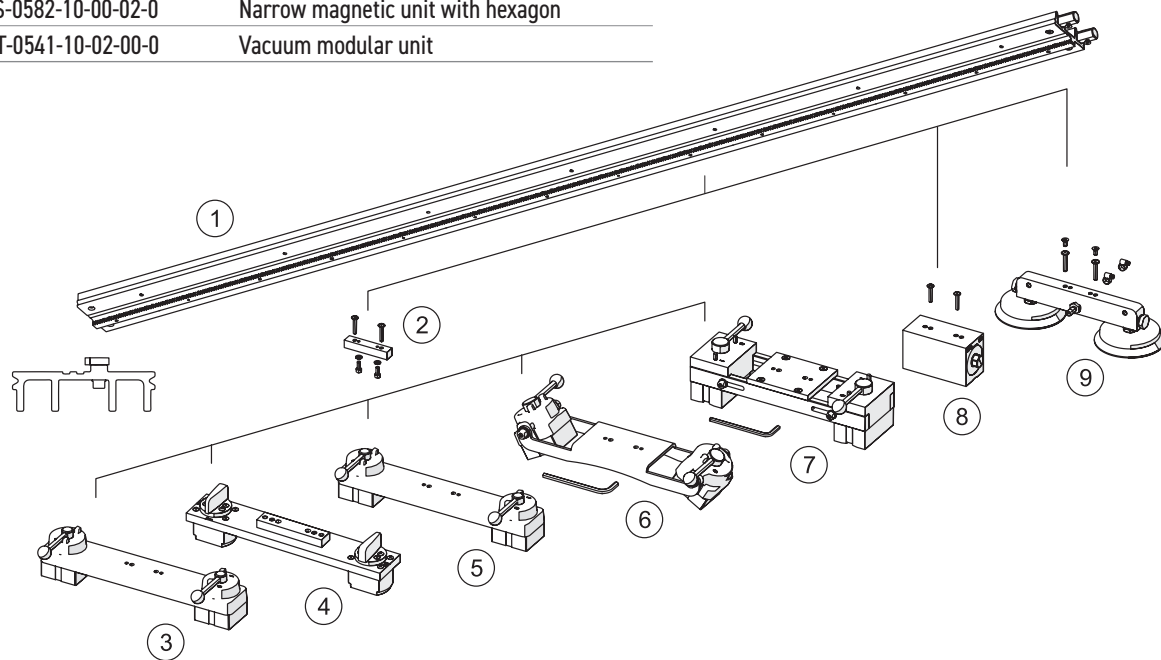
SEMI-FLEXIBLE TRACK



Ref.	Product code	Description
1	PRW-0482-15-05-00-0	Semi-flexible track length 2 m (6.5 ft). Minimum 5 m (16 ft) curvature radius required
2	DYS-0482-19-00-00-0	Bracket for magnetic units for hi-flex track and semi-flexible track
3	ZSP-0475-92-00-00-0	Magnetic unit
4	ZSP-0475-93-00-00-0	Heat-resistant magnetic unit
5	ZSP-0475-85-00-00-0	Pivoting magnetic unit
6	ZSP-0523-19-00-00-0	Spacing-adjustable magnetic unit
7	DYS-0582-10-00-00-0	Bracket for narrow magnetic unit for hi-flex track and semi-flexible track
8	PDS-0582-10-00-02-0	Narrow magnetic unit with hexagon
9	WSP-0523-12-01-00-1	Steel support for semi-flexible track
10	DYS-0541-11-01-00-0	Bracket for vacuum modular unit for hi-flex track and semi-flexible track
11	MST-0541-10-02-00-0	Vacuum modular unit
12	WSP-0541-11-02-00-0	Aluminum support for semi-flexible track

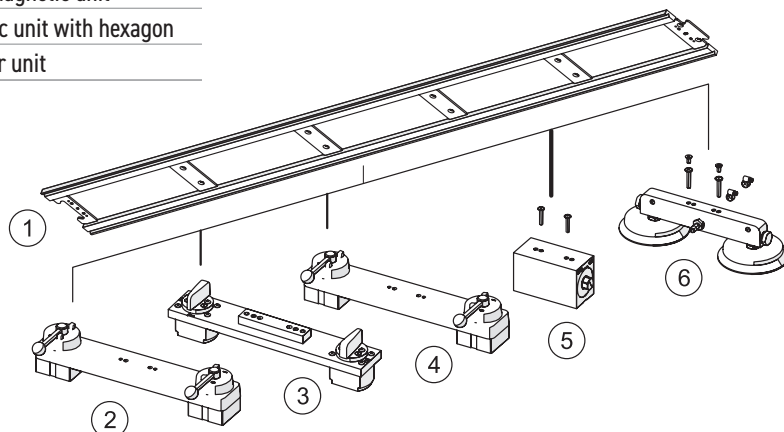
RIGID TRACK

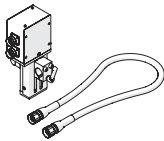
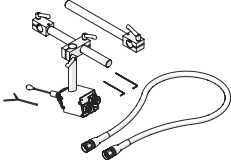
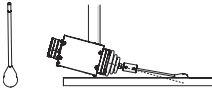
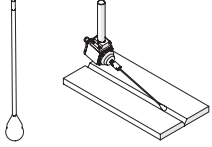
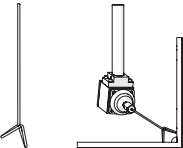
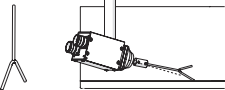
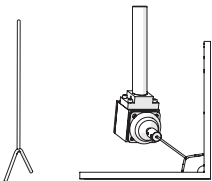
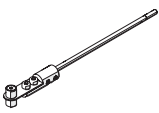
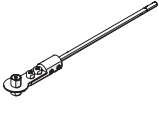
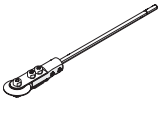

Ref.	Product code	Description
1	PRW-0482-47-00-00-0	Rigid track length 2 m (6.5 ft)
2	DYS-0482-21-00-00-0	Bracket for magnetic units for rigid track
3	ZSP-0475-92-00-00-0	Magnetic unit
4	MST-0677-00-00-00-0	Lightweight magnetic unit
5	ZSP-0475-93-00-00-0	Heat-resistant magnetic unit
6	ZSP-0475-85-00-00-0	Pivoting magnetic unit
7	ZSP-0523-19-00-00-0	Spacing-adjustable magnetic unit
8	PDS-0582-10-00-02-0	Narrow magnetic unit with hexagon
9	MST-0541-10-02-00-0	Vacuum modular unit

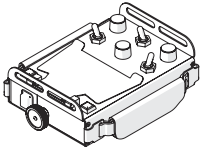
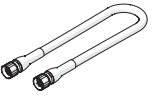



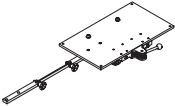
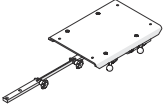
V-TRACK

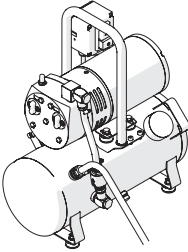

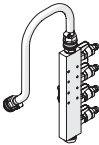
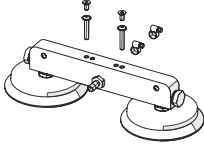
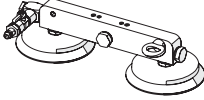
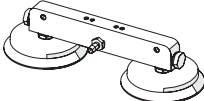
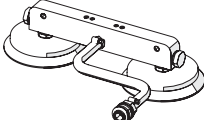
Ref.	Product code	Description
1	TRO-0475-13-00-00-0	V-track length 1,8 m
2	ZSP-0475-92-00-00-0	Magnetic unit
3	MST-0677-00-00-00-0	Lightweight magnetic unit
4	ZSP-0475-93-00-00-0	Heat-resistant magnetic unit
5	PDS-0582-10-00-02-0	Narrow magnetic unit with hexagon
6	MST-0541-10-02-00-0	Vacuum modular unit

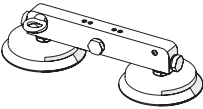
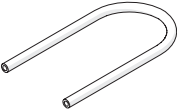
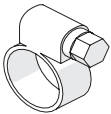
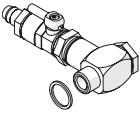
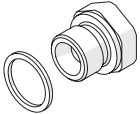
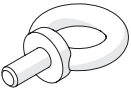

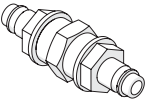
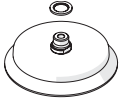
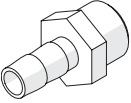
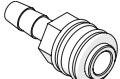


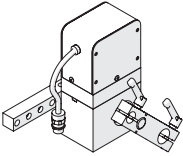
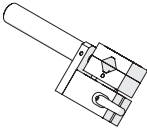
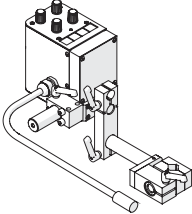
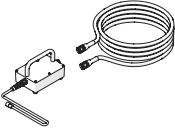


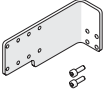
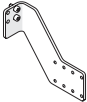

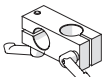
Product	Product Code / Description	Specification
	OSK-0654-04-00-00-0 Motorized vertical slide for RAIL TITAN 2	<ul style="list-style-type: none"> <li>• suitable for RAIL TITAN 2</li> <li>• automatic vertical adjustment of the torch position within the range of 0-90 mm</li> <li>• including 0.8 m cable</li> </ul>
	CZJ-0654-05-00-00-0 Seam tracking assembly for RAIL TITAN 2	<ul style="list-style-type: none"> <li>• suitable for RAIL TITAN 2</li> <li>• sensor rod 105 mm long with a ball tip 14 mm OD</li> <li>• sensor rod with a fork tip (112 mm long)</li> <li>• rod 230 mm long / 22.2 mm OD with clamping block 22.2 mm ID with lever (2 pcs.)</li> <li>• double clamping block with levers</li> <li>• including 1 m cable</li> </ul>
	ELM-0523-07-01-14-0 Sensor rod with a ball tip (short)	<ul style="list-style-type: none"> <li>• suitable for RAIL TITAN 2</li> <li>• sensor rod 105 mm long / 3 mm OD</li> <li>• ball tip 14 mm OD</li> </ul>
	ELM-0316-06-06-00-0 Sensor rod with a ball tip (long)	<ul style="list-style-type: none"> <li>• suitable for RAIL TITAN 2</li> <li>• sensor rod 210 mm long / 3 mm OD</li> <li>• ball tip 14 mm OD</li> </ul>
	PRT-0550-05-00-00-0 Sensor rod with a bent tip	<ul style="list-style-type: none"> <li>• suitable for RAIL TITAN 2</li> <li>• length: 213 mm</li> </ul>
	PRT-0523-07-01-16-0 Sensor rod with a fork tip (short)	<ul style="list-style-type: none"> <li>• suitable for RAIL TITAN 2</li> <li>• length: 112 mm</li> </ul>
	PRT-0550-06-00-00-0 Sensor rod with a fork tip (long)	<ul style="list-style-type: none"> <li>• suitable for RAIL TITAN 2</li> <li>• length: 192 mm</li> </ul>
	ADT-0506-40-00-00-0 Sensor rod with tip I	<ul style="list-style-type: none"> <li>• suitable for RAIL TITAN 2</li> </ul>
	ADT-0506-41-00-00-0 Sensor rod with tip II	<ul style="list-style-type: none"> <li>• suitable for RAIL TITAN 2</li> </ul>
	ADT-0506-43-00-00-0 Sensor rod with tip IV	<ul style="list-style-type: none"> <li>• suitable for RAIL TITAN 2</li> </ul>
	WSP-0523-07-01-13-0 Sensor rod for tips	<ul style="list-style-type: none"> <li>• suitable for RAIL TITAN 2</li> <li>• length: 105 mm</li> <li>• 3 mm OD</li> </ul>

Product	Product Code / Description	Specification
	PNL-0813-02-00-00-0 Remote control panel for RAIL TITAN 2	<ul style="list-style-type: none"> <li>• suitable for RAIL TITAN 2</li> </ul>
	PWD-0654-06-00-00-0 Remote control cable 0.5 m	<ul style="list-style-type: none"> <li>• length: 0.5 m</li> </ul>
	PWD-0654-04-02-00-0 Remote control cable 0.8 m	<ul style="list-style-type: none"> <li>• length: 0.8 m</li> </ul>
	PWD-0654-05-02-00-0 Remote control cable 1 m	<ul style="list-style-type: none"> <li>• length: 1 m</li> </ul>
	PWD-0654-07-00-00-0 Remote control cable 3 m	<ul style="list-style-type: none"> <li>• length: 3 m (10 ft)</li> </ul>
		PWD-0654-08-00-00-0 Remote control cable 5 m
PWD-0654-08-00-00-1 Remote control cable 10 m		<ul style="list-style-type: none"> <li>• length: 10 m (32.8 ft)</li> </ul>
PWD-0654-08-00-00-2 Remote control cable 25 m		<ul style="list-style-type: none"> <li>• length: 25 m (82 ft)</li> </ul>

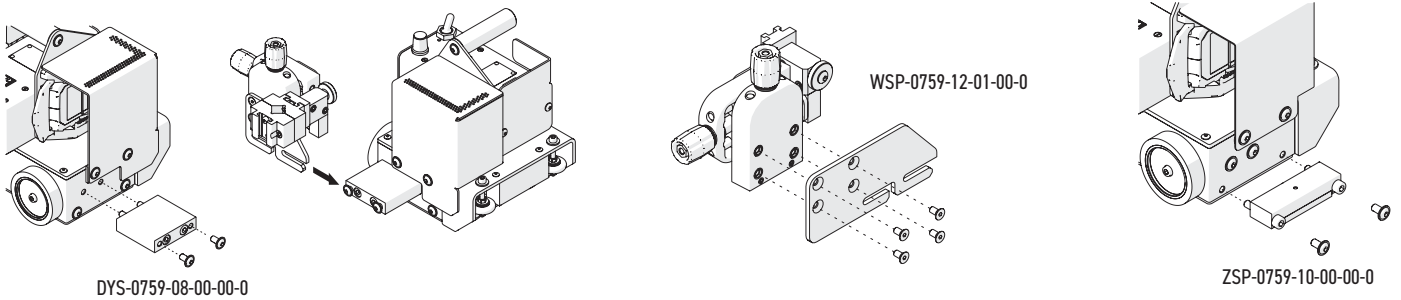
Product	Product Code / Description	Specification
	PEP-0760-10-00-00-0 Transport attachment for RAIL BULL	<ul style="list-style-type: none"> <li>• allows transporting the wire feeder</li> </ul>
	PEP-0523-93-00-00-0 Transport attachment for RAIL TITAN 2	<ul style="list-style-type: none"> <li>• allows transporting the wire feeder</li> </ul>

Product	Product Code / Description	Specification
	Portable vacuum pump with safety reservoir	<ul style="list-style-type: none"> <li>power: 400 W</li> <li>gauge pressure obtainable: -0.8 bar (-11.5 psig) (where 0 is for atmospheric pressure, and -1 is for perfect vacuum)</li> <li>pump capacity: 4 m<sup>3</sup>/h (141 ft<sup>3</sup>/h)</li> <li>generates vacuum and supports up to 21 vacuum units</li> <li>ambient temperature: 0-40°C (32-104°F)</li> <li>safety reservoir volume: 10 l (0.35 ft<sup>3</sup>)</li> <li>weight (with safety reservoir): 23 kg (51 lbs)</li> </ul>
	AGR-0541-10-20-00-0 Portable vacuum pump with safety reservoir (EU plug)	voltage: 1~ 230 V, 50-60 Hz EU plug
	AGR-0541-10-10-00-0 Portable vacuum pump with safety reservoir (UK plug)	voltage: 1~ 115 V, 50-60 Hz UK plug
	PWD-0541-06-00-00-0 Pump connection hose 10 m (32.8 ft)	<ul style="list-style-type: none"> <li>serial connection: 1 piece for the first rail track needed</li> <li>parallel connection: 1 piece per each rail track needed</li> </ul>
	RZD-0541-04-00-00-0 4-way manifold with connection cable 0.3 m (1ft)	<ul style="list-style-type: none"> <li>power and control for up to four separate vacuum circuits in parallel connection</li> <li>enables separate connections of up to four rail tracks equipped with vacuum units</li> <li>allows leapfrogging during operation</li> </ul>
	MST-0541-10-02-00-0 Vacuum modular unit	<ul style="list-style-type: none"> <li>suitable for: 160 mm wide flexible track, hi-flex track, semi-flexible track, rigid track, V-track</li> <li>allows clamping tracks on both non-ferrous and ferromagnetic materials</li> <li>maximum holding force up to 1400 N</li> <li>consists of 2 vacuum pads and manifold block</li> <li>needs bracket DYS-0541-11-01-00-0 for hi-flex track and semi-flexible track</li> <li>needs bracket DYS-0466-71-04-00-0 for wide flexible track</li> <li>depending on purpose-built configurations can function as entry, middle, extension or end vacuum unit (see below)</li> </ul>
	Entry vacuum unit Purpose-built configuration to be done on your own	purpose-built configuration including: <ul style="list-style-type: none"> <li>MST-0541-10-02-00-0 -&gt; Vacuum modular unit</li> <li>ZWR-0541-10-01-30-0 -&gt; Cut-off valve</li> <li>KRK-0541-99-00-00-0 -&gt; Threaded plug</li> <li>SRB-000365 -&gt; Safety eye bolt (option to secure the suspension)</li> </ul>
	Middle vacuum unit	purpose-built configuration including: <ul style="list-style-type: none"> <li>MST-0541-10-02-00-0 -&gt; Vacuum modular unit</li> </ul>
	Extension vacuum unit Purpose-built configuration to be done on your own For serial connection	purpose-built configuration including: <ul style="list-style-type: none"> <li>MST-0541-10-02-00-0 -&gt; Vacuum modular unit</li> <li>PWD-0541-10-04-00-0 -&gt; Coupled hose</li> <li>SRB-000365 -&gt; Safety eye bolt (option to secure the suspension)</li> </ul>

Product	Product Code / Description	Specification
	End vacuum unit Purpose-built configuration to be done on your own	purpose-built configuration including: <ul style="list-style-type: none"> <li>• MST-0541-10-02-00-0 -&gt; Vacuum modular unit</li> <li>• KRK-0541-99-00-00-0 -&gt; Threaded plug</li> <li>• SRB-000365 -&gt; Safety eye bolt (option to secure the suspension)</li> </ul>
	PWD-0541-10-07-00-0 Hose 2 m (7 ft) for connecting vacuum units within rail track	<ul style="list-style-type: none"> <li>• suitable for 1 rail track</li> <li>• to be cut to the required length between the vacuum units</li> </ul>
	OPS-000005 Hose clamp	<ul style="list-style-type: none"> <li>• 2 pieces needed to fix hose between two vacuum units</li> </ul>
	ZWR-0541-10-01-30-0 Cut-off valve for entry vacuum unit	<ul style="list-style-type: none"> <li>• serial connection: 1 piece for the first rail track needed</li> <li>• parallel connection: 1 piece per each rail track needed</li> <li>• seal included</li> </ul>
	KRK-0541-99-00-00-0 Threaded plug for end vacuum unit	<ul style="list-style-type: none"> <li>• serial connection: 1 piece for the last rail track needed</li> <li>• parallel connection: 1 piece per each rail track needed</li> </ul>
	SRB-000365 Safety eye bolt	<ul style="list-style-type: none"> <li>• option to secure the suspension</li> <li>• recommendation: 2 pieces per each rail track</li> </ul>
	PWD-0541-10-04-00-0 Coupled hose for extension vacuum unit	<ul style="list-style-type: none"> <li>• for serial connection of rail tracks</li> <li>• length: 0.21 m</li> </ul>
	LCZ-0541-05-00-00-0 Hose extension adapter	<ul style="list-style-type: none"> <li>• compatible with quick coupling</li> </ul>
	SSW-0541-99-01-00-0 Vacuum pad	<ul style="list-style-type: none"> <li>• spare part for modular vacuum unit</li> </ul>
	KRC-000013 Hose fitting	<ul style="list-style-type: none"> <li>• spare part for modular vacuum unit</li> </ul>
	SZB-000018 Quick coupling	<ul style="list-style-type: none"> <li>• spare part for pump connection hose and coupled hose</li> </ul>

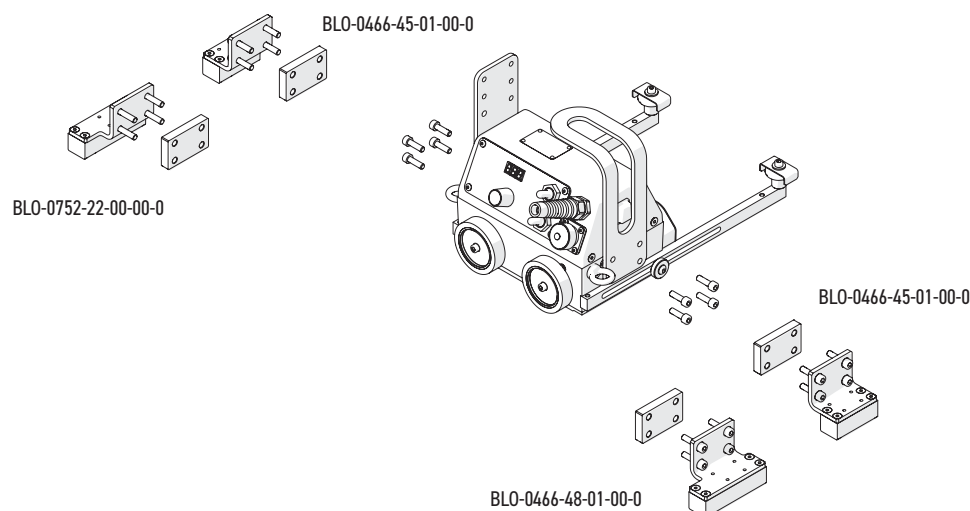
Product	Product Code / Description	Specification
	ZSP-0477-10-00-00-0 Pendulum oscillator for LIZARD	<ul style="list-style-type: none"> <li>• oscillation type: angular</li> <li>• oscillation width: 1-30 mm (1-100%) at r=150 mm (5.9")</li> <li>• oscillation speed at oscillation width of 10 mm (25/64") and zero dwell time on ends: 7-164 cycles/min (1-100%)</li> <li>• oscillation delay time: 0-5 s (at external points)</li> <li>• weld paths: trapezoid and triangle</li> <li>• maximum torque: 5 N·m</li> <li>• power: 12 W</li> <li>• weight: 2.6 kg (5.7 lbs)</li> </ul>
	UCW-0476-06-00-00-0 Short low rod torch holder with clip 16-22 mm	<ul style="list-style-type: none"> <li>• clip for welding torches ranged 16-22 mm OD</li> <li>• dowel pin 15 mm OD</li> <li>• low rod 110 mm long / 22.2 mm OD</li> <li>• clamping block 22.2 mm ID with lever</li> <li>• insulation tube 22.2 mm OD / 15 mm ID</li> <li>• for use with, among others, a pendulum oscillator</li> </ul>
	OSC-0799-10-00-00-0 Pendulum oscillator OSC-8 PRO with LED display	<ul style="list-style-type: none"> <li>• oscillation type: angular</li> <li>• oscillation width at r=150 mm (5 29/32"): 1-30 mm; 3/64"-1 3/16" (3-99%)</li> <li>• oscillation speed at oscillation width of 10 mm (3/8") and zero dwell time on ends: 12-300 cycles/min</li> <li>• dwell time on ends: 0-5 s</li> <li>• weld paths: trapezoid and triangle (standard); triangle with dwell times at both ends and square (possible in EXT mode when set up with certain products)</li> <li>• torch type: MIG/MAG</li> <li>• torch diameter: 16-22 mm (5/8"-55/64")</li> <li>• maximum torque: 8 N·m</li> <li>• voltage: 14-24 V DC</li> <li>• power: 50 W</li> <li>• weight: 2.1 kg (4.6 lbs)</li> </ul>
	ZSL-0720-03-00-05-0 Power supply for OSC-8 PRO, EU	<ul style="list-style-type: none"> <li>• includes control cable for power supply 5 m PWD-0720-02-00-00-0</li> <li>• requires optional 1 m long adapter cable PWD-0720-04-00-00-0 to extend the connection to 6 metres between power supply and OSC-8 PRO</li> <li>• voltage: 1~ 230 V, 50-60 Hz</li> <li>• EU plug</li> </ul>
	ZSL-0720-03-00-04-0 Power supply for OSC-8 PRO, D	<ul style="list-style-type: none"> <li>• voltage: 1~ 230 V, 50-60 Hz</li> <li>• D plug</li> </ul>
	ZSL-0720-03-00-01-0 Power supply for OSC-8 PRO, US	<ul style="list-style-type: none"> <li>• voltage: 1~ 115 V, 50-60 Hz</li> <li>• US plug</li> </ul>
	PWD-0720-02-00-00-0 Control cable for power supply 5 m	<ul style="list-style-type: none"> <li>• length: 5 m (16.4 ft)</li> <li>• for power supply</li> </ul>
	PWD-0720-04-00-00-0 Cable connecting adapter 1 m for OSC-8 PRO	<ul style="list-style-type: none"> <li>• length: 1 m</li> </ul>
	KTW-0805-99-01-00-0 OSC-8 PRO support for GECKO family	<ul style="list-style-type: none"> <li>• enables mounting of the OSC-8 PRO oscillator with any tractor from the GECKO family</li> <li>• incl. two screws M6 x 14</li> </ul>
	WSP-0757-11-00-00-0 OSC-8 PRO support for SCORPIO Battery	<ul style="list-style-type: none"> <li>• enables mounting of the OSC-8 PRO oscillator with SCORPIO Battery tractor</li> <li>• incl. two screws M6 x 14</li> </ul>
	KLM-0236-00-16-00-0 200 mm long rod	<ul style="list-style-type: none"> <li>• rod 200 mm long / 22.2 mm OD</li> <li>• together with KST-0525-11-00-00-0 enable mounting of the OSC-8 PRO oscillator with RAIL BULL, RAIL TUG and RAIL TITAN 2</li> </ul>
	KST-0525-11-00-00-0 Double clamping block with levers	<ul style="list-style-type: none"> <li>• two holes 22.2 mm ID</li> </ul>

Product Code	Product Description	Suitable for
DYS-0759-08-00-00-0	Bracket for opposite torch placement	MINI SPIDER Battery
PDT-0526-21-00-00-0	Cable anchor for MINI SPIDER Battery	MINI SPIDER Battery
WSP-0759-12-01-00-0	Enlarged cross-slide bracket	MINI SPIDER Battery
ZSP-0759-07-00-00-0	Cross-slide with bracket	MINI SPIDER Battery
ZSP-0759-10-00-00-0	Auxiliary magnet blocks	MINI SPIDER Battery

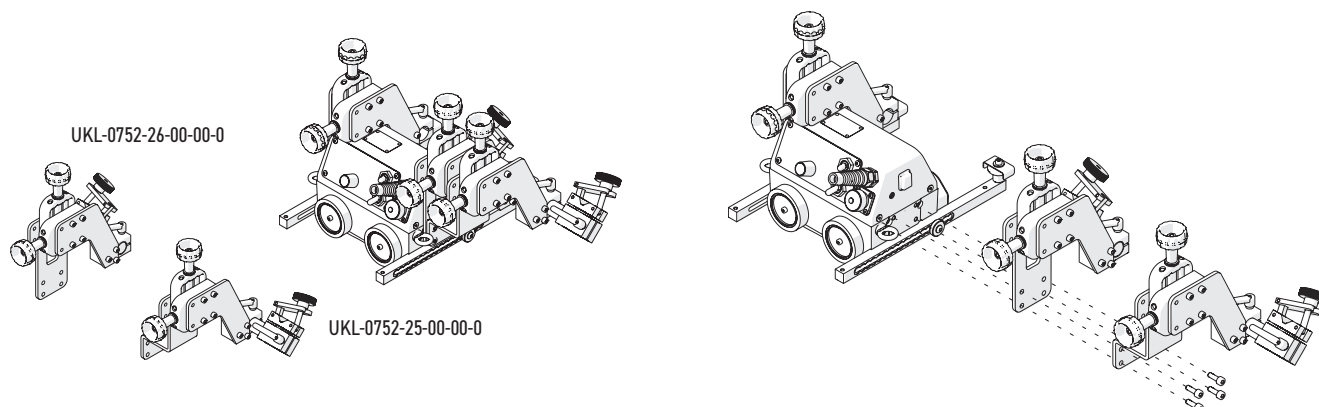


Product Code	Product Description	Suitable for
KTW-0805-99-01-00-0	OSC-8 PRO support for GECKO family	GECKO family
PRW-0466-41-00-00-1	Edge following guide arms 15 x 15 mm (set of 2 pcs)	GECKO family
PRW-0752-10-00-00-1	Adjustable guide arms 15 x 15 mm (set of 2 pcs)	GECKO family
PRW-0752-11-00-00-1	Magnet guide arms 15 x 15 mm (set of 2 pcs)	GECKO family
PRW-0752-12-00-00-1	Low guide arms 15 x 15 mm (set of 2 pcs)	GECKO family
PRW-0752-13-00-00-1	High guide arms 15 x 15 mm (set of 2 pcs)	GECKO family
PRW-0752-14-00-00-1	Following guide arms 15 x 15 mm for 36 mm wide flexible track (set of 2 pcs)	GECKO family
SRB-0466-10-00-00-0	Guide arm screw short 30 mm	GECKO family

Product Code	Product Description	Suitable for
BLO-0466-45-01-00-0	Magnet blocks (front & back) clamping force 55 N	GECKO and GECKO HS
BLO-0466-48-01-00-0	Magnet blocks (back) clamping force 80 N	GECKO and GECKO HS
BLO-0752-22-00-00-0	Magnet blocks (front) clamping force 80 N	GECKO and GECKO HS

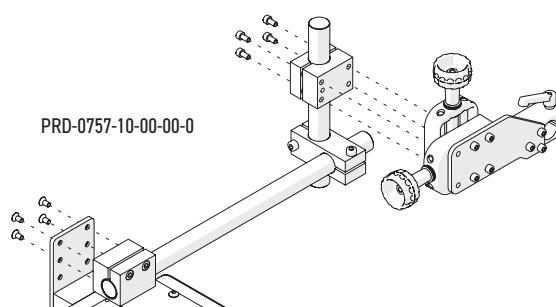


Product Code	Product Description	Suitable for
OSL-0466-29-00-00-0	Display cover for GECKO and GECKO HS	GECKO and GECKO HS
PDT-0466-55-00-00-0	Cable anchor for GECKO and GECKO HS	GECKO and GECKO HS
UKL-0752-25-00-00-0	Assembly for mounting a third torch in GECKO	GECKO and GECKO HS
UKL-0752-26-00-00-0	Assembly for mounting a second torch in GECKO	GECKO and GECKO HS



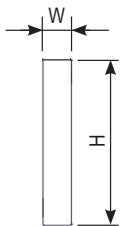
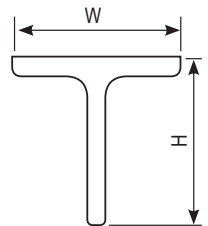
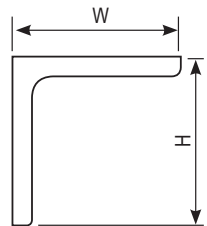
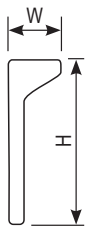
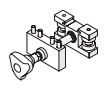
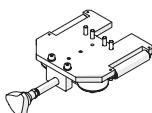
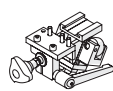
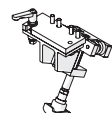
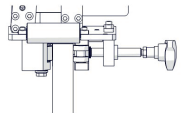
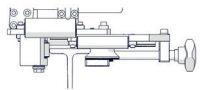
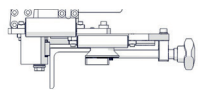
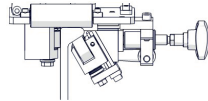
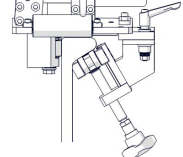
Product Code	Product Description	Suitable for
OSL-0526-22-00-00-0	Display cover for GECKO Battery 2	GECKO Battery 2

Product Code	Product Description	Suitable for
PRD-0757-10-00-00-0	Torch extension arm for SCORPIO Battery	SCORPIO Battery
WSP-0757-11-01-00-0	OSC-8 PRO support for SCORPIO Battery	SCORPIO Battery



Product Code	Product Description	Suitable for
KOL-0476-57-00-00-0	Stainless steel drive wheel for LIZARD	LIZARD
KOL-0754-01-10-00-0	Standard drive wheel for LIZARD	LIZARD
OSL-0476-23-00-00-0	Display cover for LIZARD	LIZARD
PDT-0754-12-00-00-0	Cable anchor for LIZARD	LIZARD
PRW-0476-21-00-00-1	Edge following guide arms 20 x 20 mm (set of 2 pcs)	LIZARD
PRW-0476-22-00-00-1	Adjustable guide arms 20 x 20 mm (set of 2 pcs)	LIZARD
PRW-0476-50-01-00-1	Following guide arms 20 x 20 mm for 36 mm wide flexible track (set of 2 pcs)	LIZARD
PRW-0476-52-00-00-1	Magnet guide arms 20 x 20 mm (set of 2 pcs)	LIZARD
PRW-0476-54-00-00-1	Low guide arms 20 x 20 mm (set of 2 pcs)	LIZARD
PRW-0476-55-00-00-1	High guide arms 20 x 20 mm (set of 2 pcs)	LIZARD
PRW-0476-56-00-00-0	Standard guide arms 20 x 20 mm (set of 2 pcs)	LIZARD
SRB-0476-08-00-00-0	Guide arm screw long 40 mm	LIZARD
ZSP-0477-10-00-00-0	Pendulum oscillator for LIZARD	LIZARD

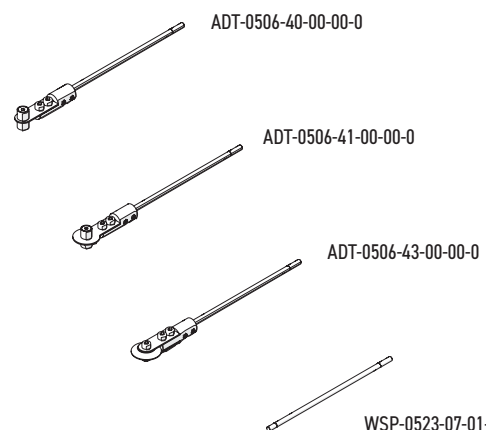
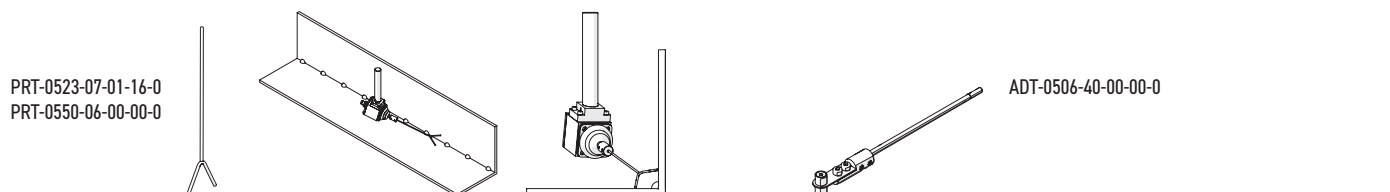
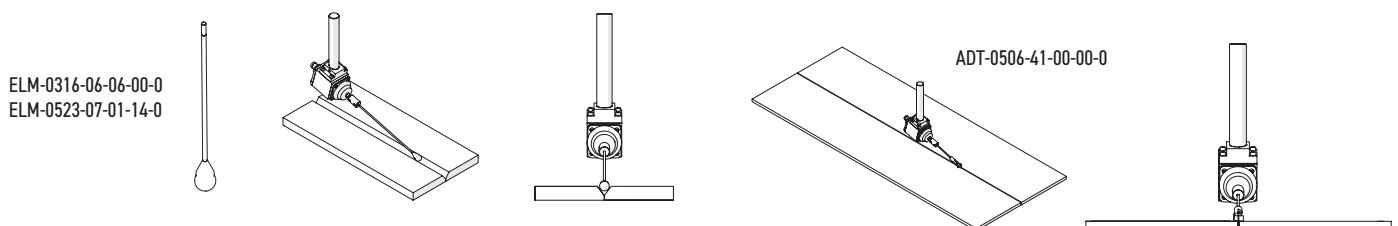
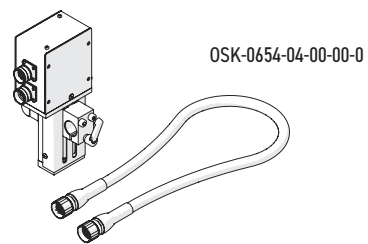
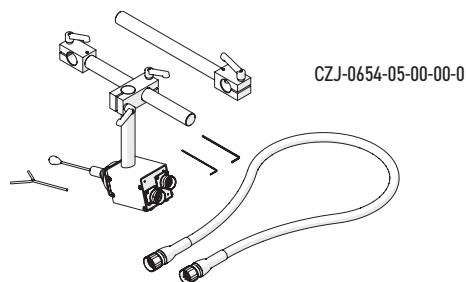
Product Code	Product Description	Suitable for
DCS-0824-0037-00-0	Clamp for flat profiles (option)	MANTIS Battery
DCS-0824-0037-01-0	Clamp for T profiles and angle profiles (option)	MANTIS Battery
DCS-0824-0037-02-0	Small clamp for bulb profiles 50 – 180 mm (option)	MANTIS Battery
DCS-0824-0037-03-0	Large clamp for bulb profiles 200 – 340 mm (option)	MANTIS Battery
PWG-0833-05-00-00-0	Counterweight 1.3 kg (2.9 lbs) with screw	MANTIS Battery
PWG-0833-06-00-00-0	Large counterweight 2,6 kg (5,7 lbs) with screw	MANTIS Battery
UCW-0466-55-03-00-0	Cable anchor for MANTIS Battery	MANTIS Battery
UKL-0824-0974-01-0	Cross slide assembly "Right"	MANTIS Battery
UKL-0824-1051-01-0	Cross slide assembly "Left"	MANTIS Battery
ZSP-0475-94-00-00-0	Double sliding clamping block	MANTIS Battery

			
W = max. 50 mm H = min. 50 mm	W = 55-120 mm H = min. 50 mm		W = 200-340 mm H = min. 80 mm
 DCS-0824-0037-00-0	 DCS-0824-0037-01-0	 DCS-0824-0037-02-0	 DCS-0824-0037-03-0
	 		

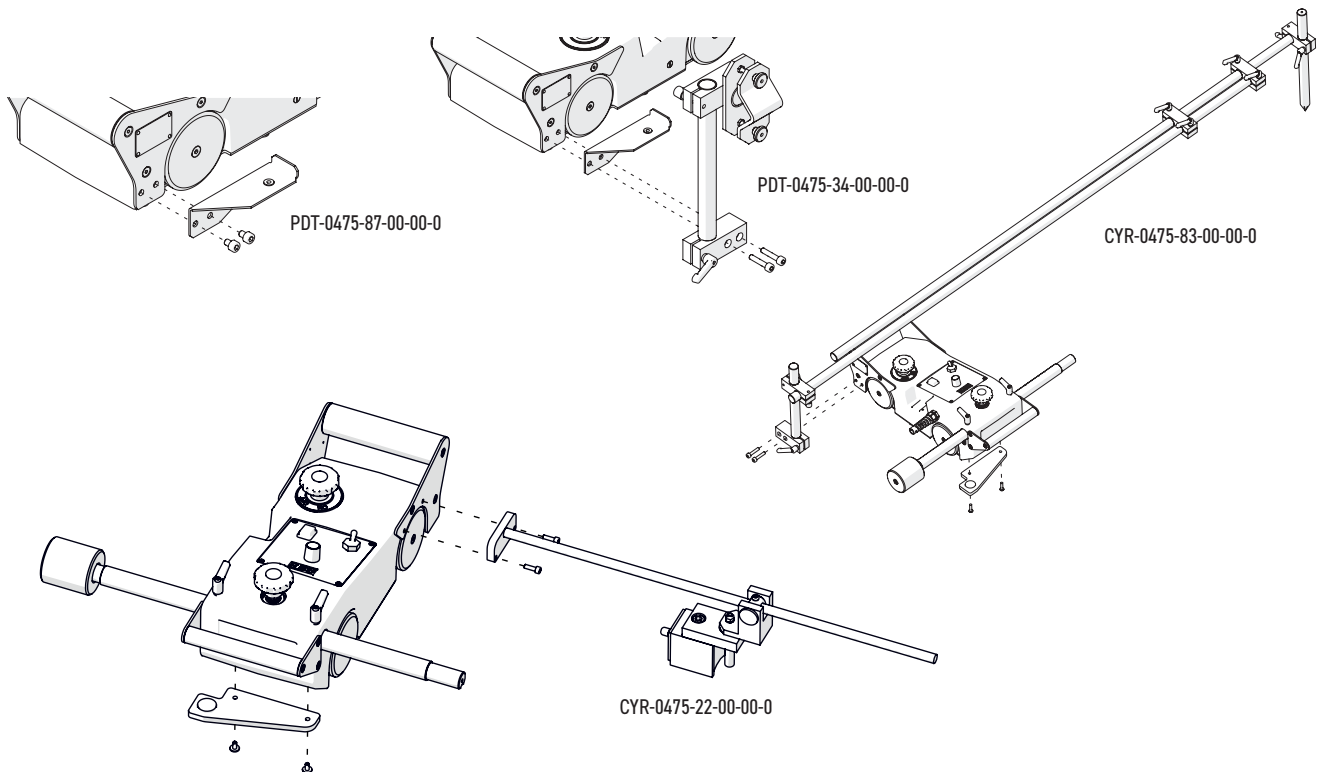
Product Code	Product Description	Suitable for
PEP-0760-10-00-00-0	Transport attachment for RAIL BULL	RAIL BULL
PRW-0482-11-00-00-0	Cross-slide assembly for RAIL BULL	RAIL BULL
WSP-0525-12-00-00-0	Gas manifold bracket for RAIL BULL	RAIL BULL
WSP-0760-06-00-00-0	Cable anchor for RAIL BULL	RAIL BULL

Product Code	Product Description	Suitable for
UCW-0523-05-01-00-0	Cable anchor for RAIL TUG	RAIL TUG

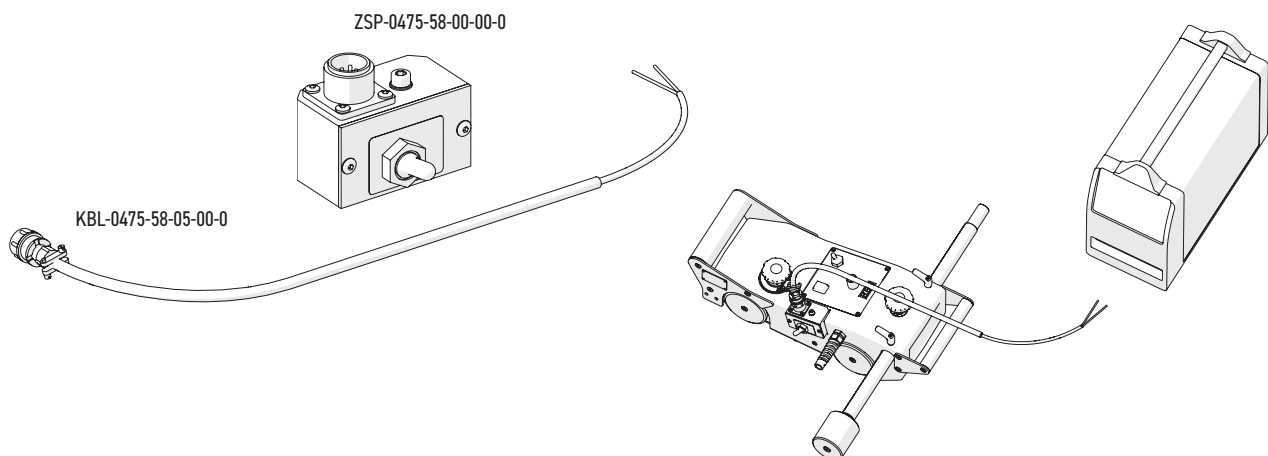
Product Code	Product Description	Suitable for
ADT-0506-40-00-00-0	Sensor rod with tip I	RAIL TITAN 2
ADT-0506-41-00-00-0	Sensor rod with tip II	RAIL TITAN 2
ADT-0506-43-00-00-0	Sensor rod with tip IV	RAIL TITAN 2
CZJ-0654-05-00-00-0	Seam tracking assembly for RAIL TITAN 2	RAIL TITAN 2
ELM-0316-06-06-00-0	Sensor rod with a ball tip (long)	RAIL TITAN 2
ELM-0523-07-01-14-0	Sensor rod with a ball tip (short)	RAIL TITAN 2
OSK-0654-04-00-00-0	Motorized vertical slide for RAIL TITAN 2	RAIL TITAN 2
PNL-0813-02-00-00-0	Remote control panel for RAIL TITAN 2	RAIL TITAN 2
PRT-0523-07-01-16-0	Sensor rod with a fork tip (short)	RAIL TITAN 2
PRT-0550-05-00-00-0	Sensor rod with a bent tip	RAIL TITAN 2
PRT-0550-06-00-00-0	Sensor rod with a fork tip (long)	RAIL TITAN 2
PWD-0654-06-00-00-0	Remote control cable 0.5 m	RAIL TITAN 2
PWD-0654-07-00-00-0	Remote control cable 3 m	RAIL TITAN 2
PWD-0654-08-00-00-0	Remote control cable 5 m	RAIL TITAN 2
PWD-0654-08-00-00-1	Remote control cable 10 m	RAIL TITAN 2
PWD-0654-08-00-00-2	Remote control cable 25 m	RAIL TITAN 2
UCW-0654-02-00-00-0	Cable anchor for RAIL TITAN 2	RAIL TITAN 2
WSP-0523-07-01-13-0	Sensor rod for tips	RAIL TITAN 2



Product Code	Product Description	Suitable for
CYR-0475-22-00-00-0	Circle cutting attachment	DRAGON family
CYR-0475-83-00-00-0	Circle cutting attachment (extended)	DRAGON family
OSL-0475-54-00-00-0	Heat protection shield (left)	DRAGON family
OSL-0475-55-00-00-0	Heat protection shield (right)	DRAGON family
OSL-0753-20-00-00-0	Heat protection shield (bottom)	DRAGON family
PDT-0475-34-00-00-0	Cable anchor for DRAGON family	DRAGON family
PDT-0475-87-00-00-0	Gas manifold bracket for DRAGON family	DRAGON family
TRO-0475-13-00-00-0	V-track	DRAGON family



Product Code	Product Description	Suitable for
KBL-0475-58-05-00-0	Arc ignition cable for plasma	DRAGON HS
ZSP-0475-58-00-00-0	Plasma arc ignition	DRAGON HS

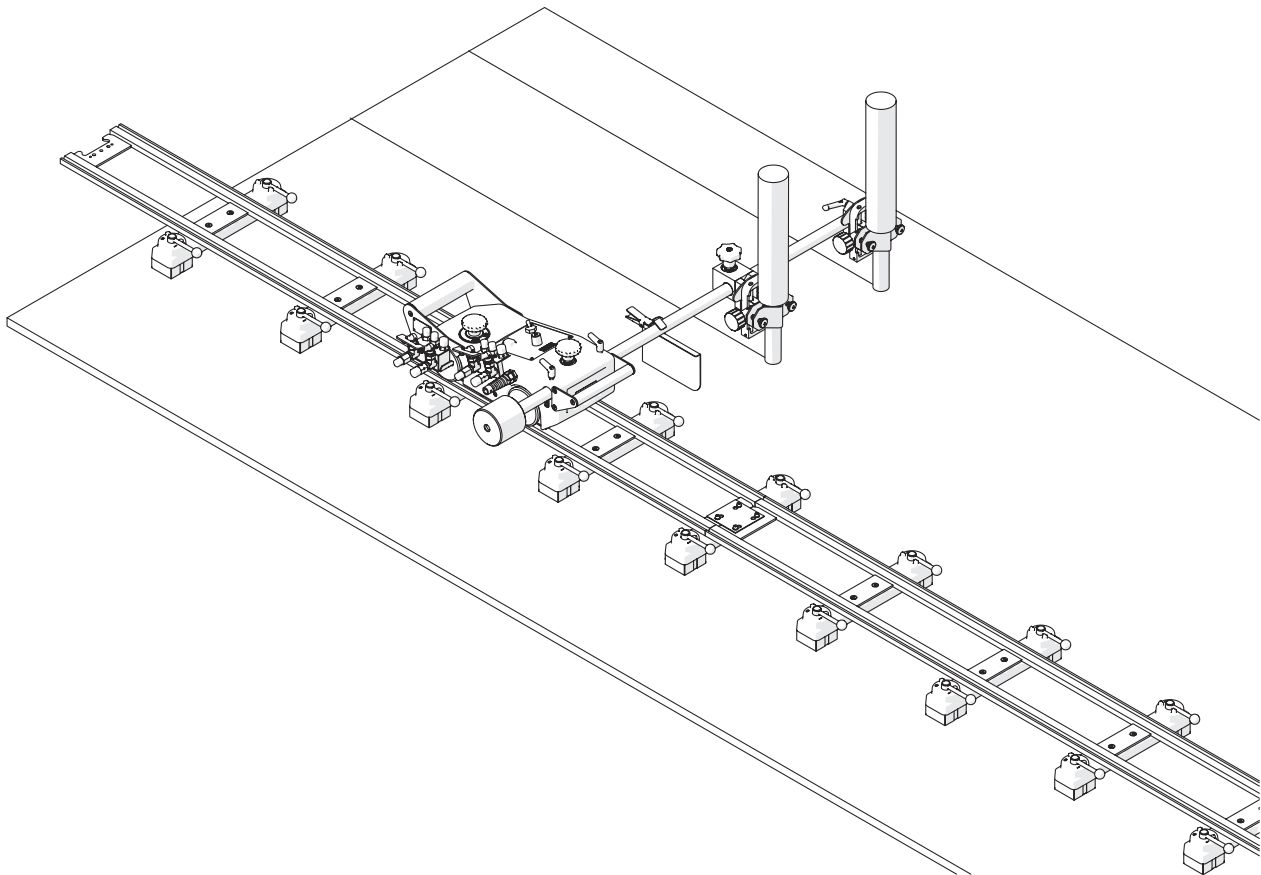


Product Code	Product Description	Page	Product Code	Product Description	Page
ADT-0506-40-00-00-0	Sensor rod with tip I	28, 36, 49	KRK-0541-99-00-00-0	Threaded plug for end vacuum unit	31
ADT-0506-41-00-00-0	Sensor rod with tip II	28, 36, 49	KST-0475-82-00-00-0	Clamping block (large)	7
ADT-0506-43-00-00-0	Sensor rod with tip IV	28, 36, 49	KST-0525-11-00-00-0	Double clamping block with levers	5, 32
ADT-0744-13-00-00-0	Cross-slide adapter for torch stand	46	KTW-0805-99-01-00-0	OSC-8 PRO support for GECKO family	32, 33
AGR-0541-10-10-00-0	Portable vacuum pump with safety reservoir, UK plug	30	LCZ-0541-05-00-00-0	Hose extension adapter	31
AGR-0541-10-20-00-0	Portable vacuum pump with safety reservoir, EU plug	30	LDW-0738-04-00-30-0	Quick Charger ASC 145, "AIR COOLED", UK plug	10
AKM-0738-10-00-01-0	Battery LiHD 18 V 4.0 Ah	10	LDW-0738-10-00-30-0	Quick Charger ASC 145, "AIR COOLED", EU plug	10
AKM-0738-10-00-02-0	Battery LiHD 18 V 10.0 Ah	10	MST-0541-10-02-00-0	Vacuum modular unit	15, 21, 30
AKM-0738-10-00-03-0	Battery LiHD 18 V 5.5 Ah	10	MST-0677-00-00-00-0	Lightweight magnetic unit	20
BLO-0466-45-01-00-0	Magnet blocks (front & back) clamping force 55 N	19, 33	OPS-000005	Hose clamp	31
BLO-0466-48-01-00-0	Magnet blocks (back) clamping force 80 N	19, 33	OSC-0799-10-00-00-0	Pendulum oscillator OSC -8 PRO with display	32
BLO-0466-68-00-00-0	Magnetic block for 36 mm wide flexible track	14	OSK-0654-04-00-00-0	Motorized vertical slide for RAIL TITAN 2	28, 36, 47
BLO-0752-22-00-00-0	Magnet blocks (front) clamping force 80 N	19, 33	OSL-0466-29-00-00-0	Display cover for GECKO and GECKO HS	13, 34
CYR-0475-22-00-00-0	Circle cutting attachment	9, 37	OSL-0475-54-00-00-0	Heat protection shield (left)	13, 37
CYR-0475-83-00-00-0	Circle cutting attachment (extended)	9, 37	OSL-0475-55-00-00-0	Heat protection shield (right)	13, 37
CZJ-0654-05-00-00-0	Seam tracking assembly for RAIL TITAN 2	28, 36, 47	OSL-0476-23-00-00-0	Display cover for LIZARD	13, 34
DCS-0824-0037-00-0	Clamp for flat profiles	35	OSL-0526-22-00-00-0	Display cover for GECKO Battery 2	13, 34
DCS-0824-0037-01-0	Clamp for T profiles and angle profiles	35	OSL-0753-20-00-00-0	Heat protection shield (bottom)	13, 37
DCS-0824-0037-02-0	Small clamp for bulb profiles 50 - 180 mm	35	OSL-0788-08-00-00-0	Enlarged battery shield	13
DCS-0824-0037-03-0	Large clamp for bulb profiles 200 - 340 mm	35	PDS-0582-10-00-02-0	Narrow magnetic unit with hexagon	15, 21
DYS-0466-71-04-00-0	Bracket for vacuum modular unit for 160 mm wide flexible track	15	PDT-0466-40-00-00-0	Dual torch mount	3
DYS-0466-71-05-00-0	Bracket for magnetic units for 160 mm wide flexible track	15	PDT-0466-55-00-00-0	Cable anchor for GECKO and GECKO HS	12, 34
DYS-0466-71-07-00-0	Bracket for narrow magnetic unit for 160 mm wide flexible track	15	PDT-0475-26-00-00-0	Roller supporter	7
DYS-0482-19-00-00-0	Bracket for magnetic units for hi-flex track and semi-flexible track	21	PDT-0475-34-00-00-0	Cable anchor for DRAGON family	12, 37
DYS-0482-21-00-00-0	Bracket for magnetic units for rigid track	22	PDT-0475-87-00-00-0	Gas manifold bracket for DRAGON family	8, 37
DYS-0523-14-14-00-0	Bracket for ring track supports	24	PDT-0526-21-00-00-0	Cable anchor for MINI SPIDER Battery	12, 33
DYS-0541-11-01-00-0	Bracket for vacuum modular unit for hi-flex track and semi-flexible track	22	PDT-0754-12-00-00-0	Cable anchor for LIZARD	12, 34
DYS-0582-10-00-00-0	Bracket for narrow magnetic unit for hi-flex track and semi-flexible track	21	PDT-0776-04-00-00-0	Cable anchor for GECKO Battery 2 and SCORPIO Battery	12
DYS-0759-08-00-00-0	Bracket for opposite torch placement	11, 33	PEP-0523-93-00-00-0	Transport attachment for RAIL TITAN 2	29
ELM-0316-06-06-00-0	Sensor rod with a ball tip (long)	28, 36, 47	PEP-0760-10-00-00-0	Transport attachment for RAIL BULL	29, 35
ELM-0523-07-01-14-0	Sensor rod with a ball tip (short)	28, 36, 47	PKT-0341-13-00-00-0	Gear rack adjustment tool	22
KBL-0466-17-00-00-0	Start-Stop arc ignition cable 6.5 m	10, 47	PLY-0341-12-03-00-0	Connecting plate for semi-flexible track	22
KBL-0466-17-00-04-0	Start-Stop arc ignition cable 13 m	10, 48	PNL-0813-02-00-00-0	Remote control panel for RAIL TITAN 2	29, 36
KBL-0475-58-05-00-0	Arc ignition cable for plasma	9, 37	PNL-0736-23-00-00-0	Remote control pendant for SWSO	47
KLM-0236-00-16-00-0	200 mm long rod	5, 32	PRD-0466-43-00-00-0	Torch extension arm for GECKO family and LIZARD	5
KOL-0466-72-00-00-0	Stainless steel drive wheel for GECKO family and SCORPIO Battery	19	PRD-0757-10-00-00-0	Torch extension arm for SCORPIO Battery	5, 34
KOL-0476-57-00-00-0	Stainless steel drive wheel for LIZARD	19, 34	PRT-0523-07-01-16-0	Sensor rod with a fork tip (short)	28, 36, 49
KOL-0752-01-04-00-0	Standard drive wheel for GECKO family and SCORPIO Battery	19	PRT-0550-05-00-00-0	Sensor rod with a bent tip	28, 36, 49
KOL-0754-01-10-00-0	Standard drive wheel for LIZARD	19, 34	PRT-0550-06-00-00-0	Sensor rod with a fork tip (long)	28, 36, 49
KRC-000013	Hose fitting	31	PRW-0466-41-00-00-1	Edge following guide arms 15 x 15 mm (2 pcs)	17, 33
			PRW-0466-50-01-01-0	36 mm wide flexible track	14
			PRW-0466-71-00-00-0	160 mm wide flexible track	14
			PRW-0476-21-00-00-1	Edge following guide arms 20 x 20 mm (2 pcs)	18, 34
			PRW-0476-22-00-00-1	Adjustable guide arms 20 x 20 mm (2 pcs)	18, 34
			PRW-0476-50-01-00-1	Following guide arms 20 x 20 mm for 36 mm wide flexible track (2 pcs)	14, 18, 34
			PRW-0476-52-00-00-1	Magnet guide arms 20 x 20 mm (2 pcs)	18, 34
			PRW-0476-54-00-00-1	Low guide arms 20 x 20 mm (2 pcs)	18, 34

Product Code	Product Description	Page	Product Code	Product Description	Page
PRW-0476-55-00-0-1	High guide arms 20 x 20 mm (2 pcs)	18, 34	RZD-0541-04-00-0-0	4-way manifold with connection cable 0.3 m	30
PRW-0476-56-00-0-0	Standard guide arms 20 x 20 mm (2 pcs)	18, 34	SKR-0523-75-04-00-0	Big wooden box for ring tracks	24
PRW-0482-11-00-0-0	Cross-slide assembly for RAIL BULL	11, 35	SKR-0523-75-05-00-0	Small wooden box for ring tracks	24
PRW-0482-15-05-00-0	Semi-flexible track	20	SLP-0233-13-02-00-1	150 mm long rod	5
PRW-0482-47-00-0-0	Rigid track	20	SRB-000365	Safety eye bolt	31
PRW-0752-10-00-0-1	Adjustable guide arms 15 x 15 mm (2 pcs)	17, 33	SRB-0466-10-00-0-0	Guide arm screw short 30 mm	17, 33
PRW-0752-11-00-0-1	Magnet guide arms 15 x 15 mm (2 pcs)	17, 33	SRB-0476-08-00-0-0	Guide arm screw long 40 mm	18, 34
PRW-0752-12-00-0-1	Low guide arms 15 x 15 mm (2 pcs)	17, 33	SSW-0541-99-01-00-0	Vacuum pad	31
PRW-0752-13-00-0-1	High guide arms 15 x 15 mm (2 pcs)	17, 33	STJ-0744-10-00-02-0	Torch Stand	47, 48
PRW-0752-14-00-0-1	Following guide arms 15 x 15 mm for 36 mm wide flexible track (2 pcs)	14, 17, 33	STJ-0744-10-00-01-0	Torch Stand XL	47, 48
PWD-0466-18-00-0-0	Power cord 230 V (EU plug) 3 m	10	SZB-000018	Quick coupling	31
PWD-0466-28-00-0-0	Power cord 115 V (UK plug) 3 m	10	TLJ-0419-04-02-03-0	Isolation tube for welding torch	5
PWD-0541-06-00-0-0	Pump connection hose 10 m	30	TRM-0476-06-10-00-0	Lower rod clamp	4
PWD-0541-10-04-00-0	Coupled hose for extension vacuum unit	31	TRO-0475-13-00-00-0	V-track	20, 37
PWD-0541-10-07-00-0	Hose 2 m for connecting vacuum units within rail track	31	TRO-0523-14-00-00-0	Ring track OD 200-250 mm	23
PWD-0654-04-02-00-0	Remote control cable 0.8 m	29	TRO-0523-20-00-00-0	Ring track OD 300-350 mm	23
PWD-0654-05-02-00-0	Remote control cable 1 m	29	TRO-0523-21-00-00-0	Ring track OD 350-400 mm	23
PWD-0654-06-00-0-0	Remote control cable 0.5 m	29, 36	TRO-0523-22-00-00-0	Ring track OD 600-650 mm	23
PWD-0654-07-00-0-0	Remote control cable 3 m	29, 36	TRO-0523-23-00-00-0	Ring track OD 400-450 mm	23
PWD-0654-08-00-0-0	Remote control cable 5 m	29, 36	TRO-0523-24-00-00-0	Ring track OD 450-500 mm	23
PWD-0654-08-00-0-1	Remote control cable 10 m	29, 36	TRO-0523-25-00-00-0	Ring track OD 500-550 mm	23
PWD-0654-08-00-0-2	Remote control cable 25 m	29, 36	TRO-0523-26-00-00-0	Ring track OD 550-600 mm	23
PWD-0720-02-00-0-0	Control cable for power supply 5 m	32	TRO-0523-28-00-00-0	Ring track OD 650-700 mm	23
PWD-0720-04-00-0-0	Cable connecting adapter 1 m for OSC-8 PRO	32	TRO-0523-29-00-00-0	Ring track OD 700-750 mm	23
PWD-0736-30-00-0-0	Transmission cable 3 m	47, 49	TRO-0523-30-00-00-0	Ring track OD 750-800 mm	23
PWD-0736-30-00-01-0	Transmission cable 5 m	49	TRO-0523-31-00-00-0	Ring track OD 800-850 mm	23
PWD-0736-30-00-02-0	Transmission cable 10 m	49	TRO-0523-32-00-00-0	Ring track OD 850-900 mm	23
PWG-0753-09-00-0-0	Counterweight 1.3 kg (2.9 lbs)	9	TRO-0523-33-00-00-0	Ring track OD 900-950 mm	23
PWG-0753-12-00-0-0	Large counterweight 2,6 kg (5,7 lbs)	9	TRO-0523-34-00-00-0	Ring track OD 950-1000 mm	23
PWG-0833-05-00-0-0	Counterweight 1.3 kg (2.9 lbs) with screw	9, 35	TRO-0523-35-00-00-0	Ring track OD 1000-1050 mm	23
PWG-0833-06-00-0-0	Large counterweight 2,6 kg (5,7 lbs) w. screw	9, 35	TRO-0523-36-00-00-0	Ring track OD 1050-1100 mm	23
RAM-0475-07-01-00-0	300 mm long rod with 241 mm geared rack	7	TRO-0523-37-00-00-0	Ring track OD 1100-1150 mm	23
RAM-0475-07-03-00-0	700 mm long rod with 647 mm geared rack	7	TRO-0523-38-00-00-0	Ring track OD 1150-1200 mm	23
RAM-0523-17-00-0-0	300 mm long rod with 182 mm geared rack	7	TRO-0523-39-00-00-0	Ring track OD 1200-1250 mm	23
RAM-0753-07-00-0-0	540 mm long rod with 449 mm geared rack	7	TRO-0523-40-00-00-0	Ring track OD 1250-1300 mm	23
RAM-0753-13-00-0-0	1000 mm long rod with 940 mm geared rack	7	TRO-0523-41-00-00-0	Ring track OD 1300-1350 mm	23
RZD-0475-63-00-0-0	Manifold 2x3 (metric)	8	TRO-0523-42-00-00-0	Ring track OD 1350-1400 mm	23
RZD-0475-64-00-0-0	Manifold 2x2 (metric)	8	TRO-0523-43-00-00-0	Ring track OD 1400-1450 mm	23
RZD-0475-65-00-0-0	Manifold 2x2 with cut-off valve (metric)	8	TRO-0523-44-00-00-0	Ring track OD 1450-1500 mm	23
RZD-0475-66-00-0-0	Manifold 2x3 with cut-off valve (metric)	8	TRO-0523-45-00-00-0	Ring track OD 1500-1550 mm	23
RZD-0475-67-00-0-0	Manifold 2x3 (imperial)	8	TRO-0523-46-00-00-0	Ring track OD 1550-1600 mm	23
RZD-0475-68-00-0-0	Manifold 2x2 (imperial)	8	TRO-0523-47-00-00-0	Ring track OD 1600-1650 mm	23
RZD-0475-69-00-0-0	Manifold 2x3 with cut-off valve (imperial)	8	TRO-0523-48-00-00-0	Ring track OD 1650-1700 mm	23
RZD-0475-70-00-0-0	Manifold 2x2 with cut-off valve (imperial)	8	TRO-0523-49-00-00-0	Ring track OD 1700-1750 mm	23
RZD-0475-71-00-0-0	Manifold 3/3 with cut-off valve (imperial)	8	TRO-0523-50-00-00-0	Ring track OD 1750-1800 mm	23
RZD-0475-72-00-0-0	Manifold 3/3 with cut-off valve (metric)	8	TRO-0523-51-00-00-0	Ring track OD 1800-1850 mm	23
RZD-0475-73-00-0-0	Manifold 3/3 (imperial)	8	TRO-0523-52-00-00-0	Ring track OD 1850-1900 mm	23
RZD-0475-74-00-0-0	Manifold 3/3 (metric)	8	TRO-0523-53-00-00-0	Ring track OD 1900-1950 mm	23
			TRO-0523-54-00-00-0	Ring track OD 1950-2000 mm	23
			TRO-0523-55-00-00-0	Ring track OD 2000-2050 mm	23

Product Code	Product Description	Page	Product Code	Product Description	Page
TRO-0523-56-00-00-0	Ring track OD 2050-2100 mm	23	UST-0466-53-00-00-0	Guide adjust. tool for 36 mm wide flexible track	14
TRO-0523-57-00-00-0	Ring track OD 2100-2150 mm	23	WLK-0466-04-10-00-0	Long rod clamp	4
TRO-0523-58-00-00-0	Ring track OD 2150-2200 mm	23	WLK-0476-20-01-00-0	Short rod clamp	4
TRO-0523-59-00-00-0	Ring track OD 2200-2250 mm	23	WLK-0633-22-02-00-0	500 mm long rod	5
TRO-0523-60-00-00-0	Ring track OD 2250-2300 mm	23	WLK-0633-22-04-00-0	400 mm long rod	5
TRO-0523-61-00-00-0	Ring track OD 2300-2350 mm	23	WLK-0757-09-01-00-0	Ultra-short rod clamp	4
TRO-0523-62-00-00-0	Ring track OD 2350-2400 mm	23	WLK-0824-0973-00-0	450 mm long rod	5
TRO-0523-63-00-00-0	Ring track OD 2400-2450 mm	23	WSP-0466-71-03-00-0	Aluminium support for 160 mm wide flexible track	15
TRO-0523-64-00-00-0	Ring track OD 2450-2500 mm	23	WSP-0466-71-06-00-0	Steel support for 160 mm wide flexible track	15
TRO-0523-65-00-00-0	Ring track OD 2500-2550 mm	23	WSP-0523-07-01-13-0	Sensor rod for tips	28, 36, 49
TRO-0523-66-00-00-0	Ring track OD 2550-2600 mm	23	WSP-0523-12-01-00-1	Steel support for semi-flexible track	22
TRO-0523-67-00-00-0	Ring track OD 2600-2650 mm	23	WSP-0523-16-00-00-0	300 mm long rod	5
TRO-0523-68-00-00-0	Ring track OD 2650-2700 mm	23	WSP-0525-12-00-00-0	Gas manifold bracket for RAIL BULL	8, 35
TRO-0523-69-00-00-0	Ring track OD 2700-2750 mm	23	WSP-0541-11-02-00-0	Aluminum support for semi-flexible track	22
TRO-0523-70-00-00-0	Ring track OD 2750-2800 mm	23	WSP-0654-11-00-00-0	Ring track support with bolts	24
TRO-0523-71-00-00-0	Ring track OD 2800-2850 mm	23	WSP-0654-12-00-00-0	Ring track support with plastic feet	24
TRO-0523-72-00-00-0	Ring track OD 2850-2900 mm	23	WSP-0654-13-00-00-0	Ring track support with magnets	24
TRO-0523-73-00-00-0	Ring track OD 2900-2950 mm	23	WSP-0757-11-00-00-0	OSC-8 PRO support for SCORPIO Battery	32, 34
TRO-0523-74-00-00-0	Ring track OD 2950-3000 mm	23	WSP-0759-12-01-00-0	Enlarged cross-slide bracket	11, 33
TRO-0523-75-00-00-0	Ring track OD 3000-3050 mm	23	WSP-0760-06-00-00-0	Cable anchor for RAIL BULL	12, 35
TRO-0523-78-00-00-0	Ring track OD 250-300 mm	23	ZCS-0270-42-00-00-0	Quick-release torch clip 16-22 mm	4
TRO-0673-00-00-00-0	Hi-flex track	20	ZCS-0475-28-10-00-0	Standard torch holder incl. clamp 28-35 mm	6
UCW-0466-22-00-00-0	Long rod torch holder with clip 16-22 mm	3	ZCS-0476-06-01-00-0	Torch clip 16-22 mm	4
UCW-0466-55-03-00-0	Cable anchor for MANTIS Battery	12, 35	ZDR-0523-76-00-00-0	Contact block for semi-flexible and rigid tracks	22
UCW-0475-15-00-00-1	Sliding clamping block type 2	7	ZDR-0673-08-00-00-0	Contact block for hi-flex track	22
UCW-0475-28-00-00-0	Standard torch holder incl. clamp 28-35 mm and angle adjustment	6	ZRZ-0466-19-00-00-0	Torch clamp 22-35 mm	4
UCW-0475-29-00-00-1	Machine torch holder 35 mm (1-3/8")	6	ZRZ-0752-07-01-00-0	Torch clamp 16-22 mm	4
UCW-0475-61-00-00-0	Machine torch holder 30 mm (1-3/16")	6	ZSL-0720-03-00-01-0	Power supply for OSC-8 PRO/SWSO (115V, US)	32, 47
UCW-0476-06-00-00-0	Short low rod torch holder with clip 16-22 mm	3, 32	ZSL-0720-03-00-04-0	Power supply for OSC-8 PRO/SWSO (230V, D)	32, 47
UCW-0476-27-00-00-0	Short rod torch holder with clip 16-22 mm	3	ZSL-0720-03-00-05-0	Power supply for OSC-8 PRO/SWSO (230V, EU)	32, 47
UCW-0523-05-01-00-0	Cable anchor for RAIL TUG	12, 35	ZSP-0466-14-00-00-0	Cross-slide 0-35 mm both up-down and left-right	11, 49
UCW-0523-84-00-00-0	Quick-release short rod torch holder with clip 16-22 mm	3	ZSP-0466-46-00-00-1	Extended cross-slide 0-76 mm either up-down or left-right	11
UCW-0654-02-00-00-0	Cable anchor for RAIL TITAN 2	12, 36	ZSP-0475-58-00-00-0	Plasma arc ignition	9, 37
UCW-0752-07-00-00-0	Long rod torch holder with clamp 16-22 mm	3	ZSP-0475-62-00-00-0	Sliding clamping block type 1	7
UCW-0753-08-00-00-0	Precise torch holder incl. clamp 28-35 mm with angle and height adjustment	6	ZSP-0475-85-00-00-0	Pivoting magnetic unit	14, 21
UCW-0753-22-00-00-0	Precise machine torch holder 30 mm (1-3/16") with angle adjustment	6	ZSP-0475-92-00-00-0	Magnetic unit	14, 20
UCW-0753-24-00-00-0	Precise machine torch holder 35 mm (1-3/8") with angle adjustment	6	ZSP-0475-93-00-00-0	Heat-resistant magnetic unit	14, 21
UCW-0754-07-00-00-0	Short rod torch holder with clamp 16-22 mm	3	ZSP-0475-94-00-00-0	Double sliding clamping block	7, 35
UCW-0757-09-00-00-0	Ultra-short rod torch holder w. clamp 16-22 mm	3	ZSP-0477-10-00-00-0	Pendulum oscillator for LIZARD	32, 34
UCW-0757-12-00-00-0	Ultra-short rod torch holder w. clip 16-22 mm	3	ZSP-0523-19-00-00-0	Spacing-adjustable magnetic unit	14, 21
UKL-0752-25-00-00-0	Assembly for mounting a third torch in GECKO	4, 34	ZSP-0673-07-00-00-0	Hi-flex track guiding rollers (set of 4 pcs)	22
UKL-0752-26-00-00-0	Assembly for mounting a second torch in GECKO	4, 34	ZSP-0759-07-00-00-0	Cross-slide with bracket	11, 33
UKL-0824-0974-01-0	Cross slide assembly "Right"	11, 35	ZSP-0759-10-00-00-0	Auxiliary magnet blocks	19, 33
UKL-0824-1051-01-0	Cross slide assembly "Left"	11, 35	ZST-0466-69-00-00-0	Following guide arms for 160 mm wide flexible track (2 pcs)	15
URZ-000001	Fall arrester device	15	ZST-0752-17-00-00-1	Standard guide arms 15 x 15 mm (2 pcs)	17
			ZWR-0541-10-01-30-0	Cut-off valve for entry vacuum unit	31

## DRAGON configuration diagram I



Example configuration of a DRAGON family tractor for straight cutting of strips using 2 torches:

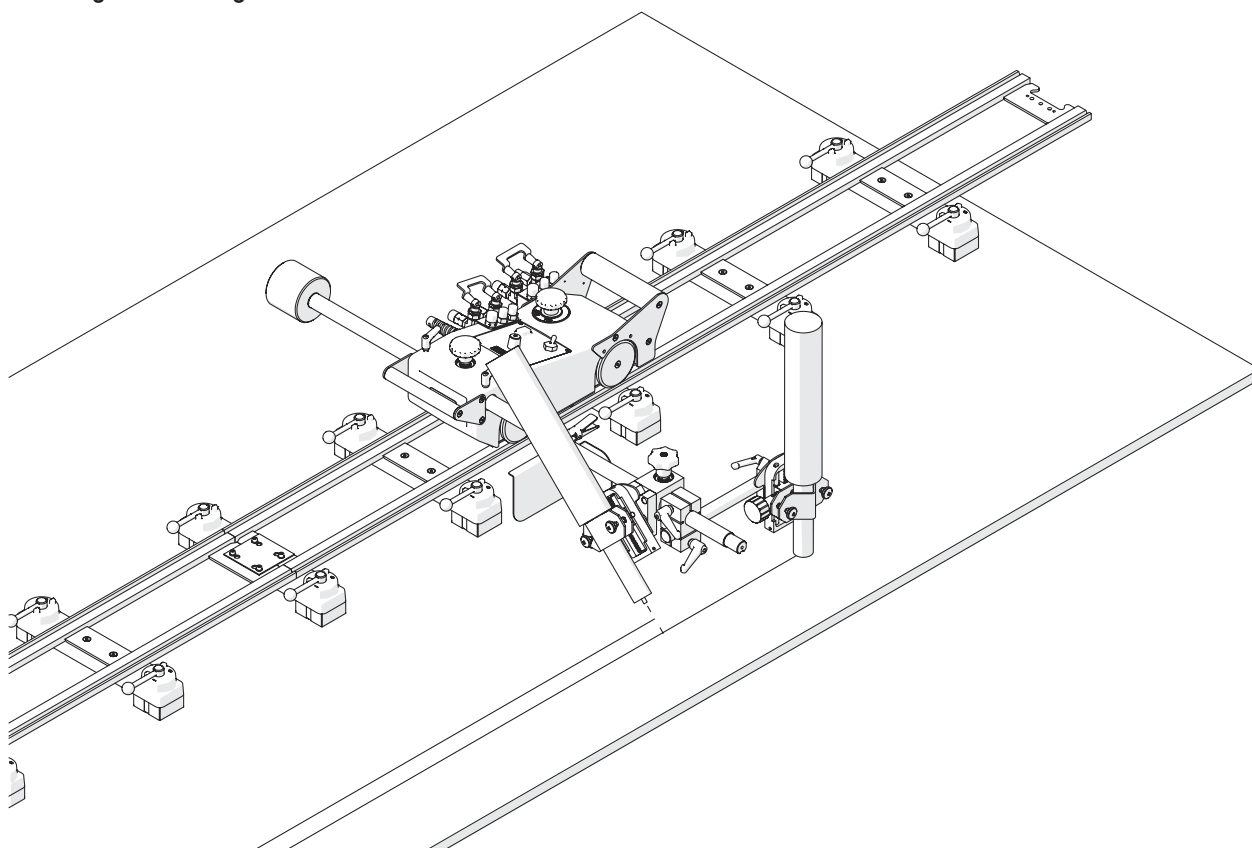
## List of optional accessories:

- TRO-0475-13-00-00-0 V-track - the number of sections, each 1800 mm long, is as many as requested
- ZSP-0475-93-00-00-0 Heat-resistant magnetic unit - the number of units depends on the total length of the V-track
- RAM-0753-13-00-00-0 1000 mm long rod with 940 mm geared rack
- PWG-0753-12-00-00-0 Large counterweight 2,6 kg (5,7 lbs)
- PDT-0475-87-00-00-0 Gas manifold bracket for DRAGON family
- RZD-0475-66-00-00-0 Manifold 2x3 with cut-off valve (metric) - 2 pieces
- OSL-0475-54-00-00-0 Heat protection shield (left)
- UCW-0475-15-00-00-1 Sliding clamping block type 2 - 2 pieces
- UCW-0753-08-00-00-0 Precise torch holder incl. clamp 28-35 mm with angle and height adjustment - 2 pieces

## Other possible accessory options:

- ZSP-0475-92-00-00-0 Magnetic unit
- MST-0677-00-00-00-0 Lightweight magnetic unit
- PDS-0582-10-00-02-0 Narrow magnetic unit with hexagon
- RAM-0475-07-03-00-0 700 mm long rod with 647 mm geared rack
- Gas Manifolds (see page 8)
- PDT-0475-34-00-00-0 Cable anchor for DRAGON family
- OSL-0475-55-00-00-0 Heat protection shield (right)
- OSL-0753-20-00-00-0 Heat protection shield (bottom)
- UCW-0475-28-00-00-0 Standard torch holder incl. clamp 28-35 mm and angle adjustment
- UCW-0475-61-00-00-0 Machine torch holder 30 mm (1-3/16")
- UCW-0475-29-00-00-1 Machine torch holder 35 mm (1-3/8")
- UCW-0753-22-00-00-0 Precise machine torch holder 30 mm (1-3/16") with angle adjustment
- UCW-0753-24-00-00-0 Precise machine torch holder 35 mm (1-3/8") with angle adjustment
- Vacuum track system (see pages 30-31)

## DRAGON configuration diagram II



Example configuration of a DRAGON family tractor for edge preparation while simultaneously straight cutting and beveling at angle using 2 torches:

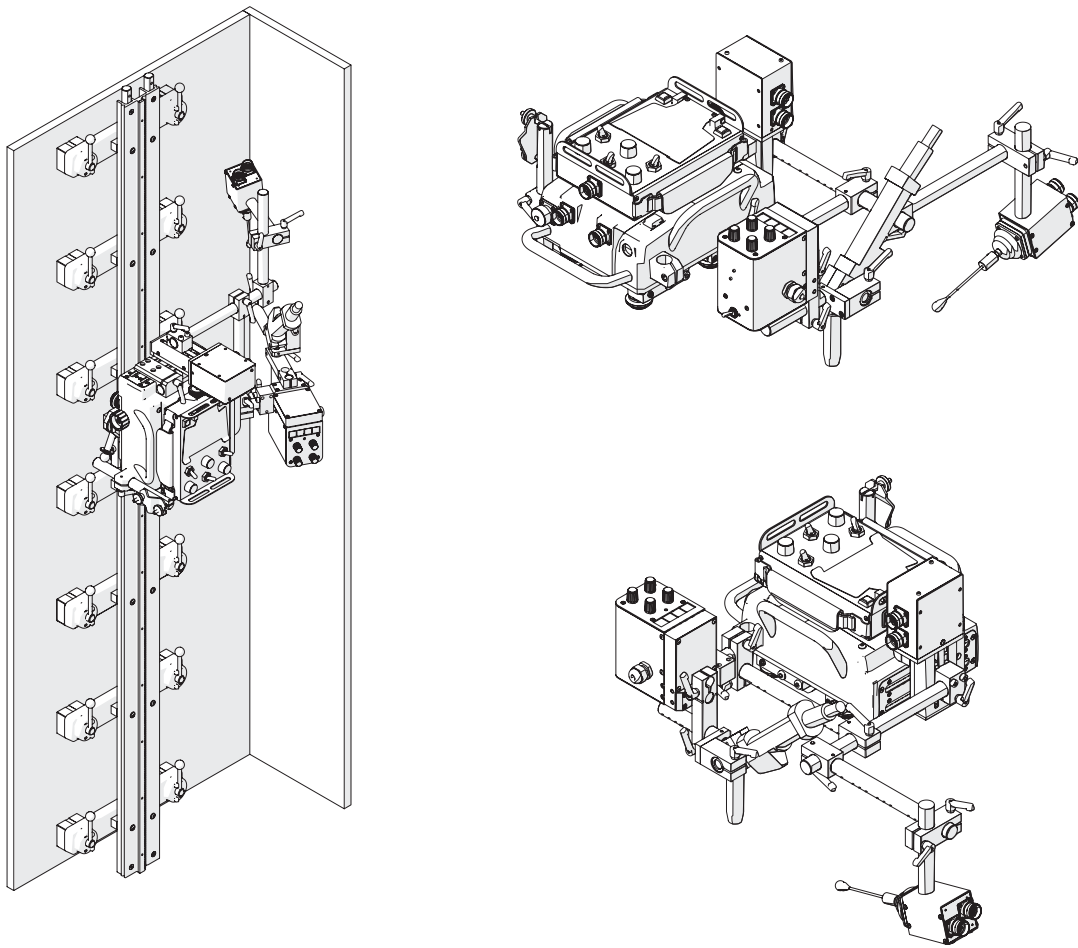
## List of optional accessories:

- TRO-0475-13-00-00-0 V-track – the number of sections, each 1800 mm long, is as many as requested
- ZSP-0475-93-00-00-0 Heat-resistant magnetic unit – the number of units depends on the total length of the V-track
- RAM-0753-13-00-00-0 1000 mm long rod with 940 mm geared rack
- PWG-0753-12-00-00-0 Large counterweight 2,6 kg (5,7 lbs)
- PDT-0475-87-00-00-0 Gas manifold bracket for DRAGON family
- RZD-0475-66-00-00-0 Manifold 2x3 with cut-off valve (metric) – 2 pieces
- OSL-0475-54-00-00-0 Heat protection shield (left)
- UCW-0475-15-00-00-1 Sliding clamping block type 2
- KST-0475-82-00-00-0 Clamping block (large)
- WSP-0523-16-00-00-0 300 mm long rod
- UCW-0753-08-00-00-0 Precise torch holder incl. clamp 28-35 mm with angle and height adjustment – 2 pieces

## Other possible accessory options:

- ZSP-0475-92-00-00-0 Magnetic unit
- MST-0677-00-00-00-0 Lightweight magnetic unit
- PDS-0582-10-00-02-0 Narrow magnetic unit with hexagon
- RAM-0475-07-03-00-0 700 mm long rod with 647 mm geared rack
- Gas Manifolds (see page 8)
- PDT-0475-34-00-00-0 Cable anchor for DRAGON family
- OSL-0475-55-00-00-0 Heat protection shield (right)
- OSL-0753-20-00-00-0 Heat protection shield (bottom)
- UCW-0475-28-00-00-0 Standard torch holder incl. clamp 28-35 mm and angle adjustment
- UCW-0475-61-00-00-0 Machine torch holder 30 mm (1-3/16")
- UCW-0475-29-00-00-1 Machine torch holder 35 mm (1-3/8")
- UCW-0753-22-00-00-0 Precise machine torch holder 30 mm (1-3/16") with angle adjustment
- UCW-0753-24-00-00-0 Precise machine torch holder 35 mm (1-3/8") with angle adjustment
- Vacuum track system (see pages 30-31)

## RAIL TITAN 2 configuration diagram



Example configuration of RAIL TITAN 2 for welding fillet joints in a vertical position using the pendulum oscillator OSC-8 PRO along with seam tracking system:

## List of optional accessories:

- PRW-0482-47-00-00-0 Rigid track - the number of sections, each 2 m long, is as many as requested
- ZSP-0475-93-00-00-0 Heat-resistant magnetic unit - the number of units depends on the total length of the rigid track
- DYS-0482-21-00-00-0 Bracket for magnetic units for rigid track - the number of brackets is the same as the number of magnetic units
- CZJ-0654-05-00-00-0 Seam tracking assembly for RAIL TITAN 2
- OSK-0654-04-00-00-0 Motorized vertical slide for RAIL TITAN 2
- OSC-0799-10-00-00-0 Pendulum oscillator OSC-8 PRO with LED display

## Other possible accessory options:

- PRW-0482-15-05-00-0 Semi-flexible track
- ZSP-0475-92-00-00-0 Magnetic unit
- DYS-0482-19-00-00-0 Bracket for magnetic units for hi-flex track and semi-flexible track
- PDS-0582-10-00-02-0 Narrow magnetic unit with hexagon
- DYS-0582-10-00-00-0 Bracket for narrow magnetic unit for hi-flex track and semi-flexible track

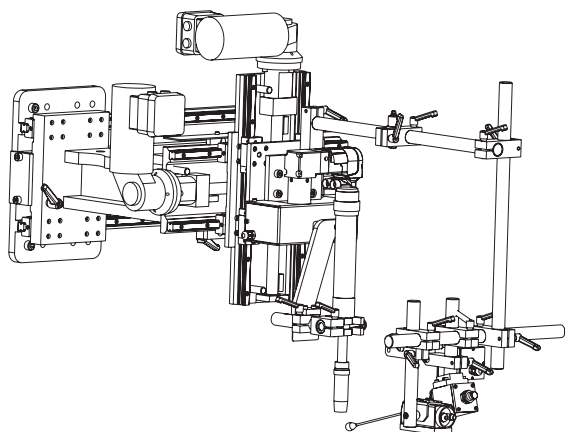
## Product

Product Code /  
Description

## Specification

UKL-0550-10-20-02-0  
JTS - Joint Tracking System

- vertical movement range - Z axis: 200 mm (7.9")
- horizontal movement range - X axis: 200 mm (7.9")
- vertical movement speed - Z axis: 360 mm/min (14.2 in/min)
- horizontal movement speed - X axis: 360 mm/min (14.2 in/min)
- weight: 45 kg (100 lbs)
- voltage: 230 V, 50/60 Hz + PE
- power: 500 W

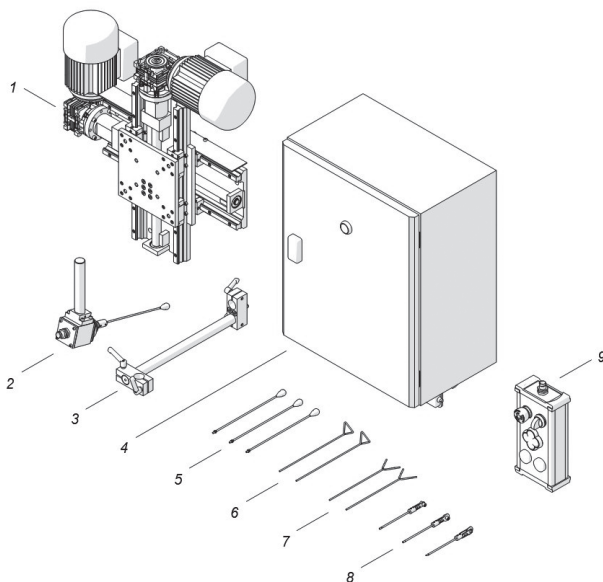
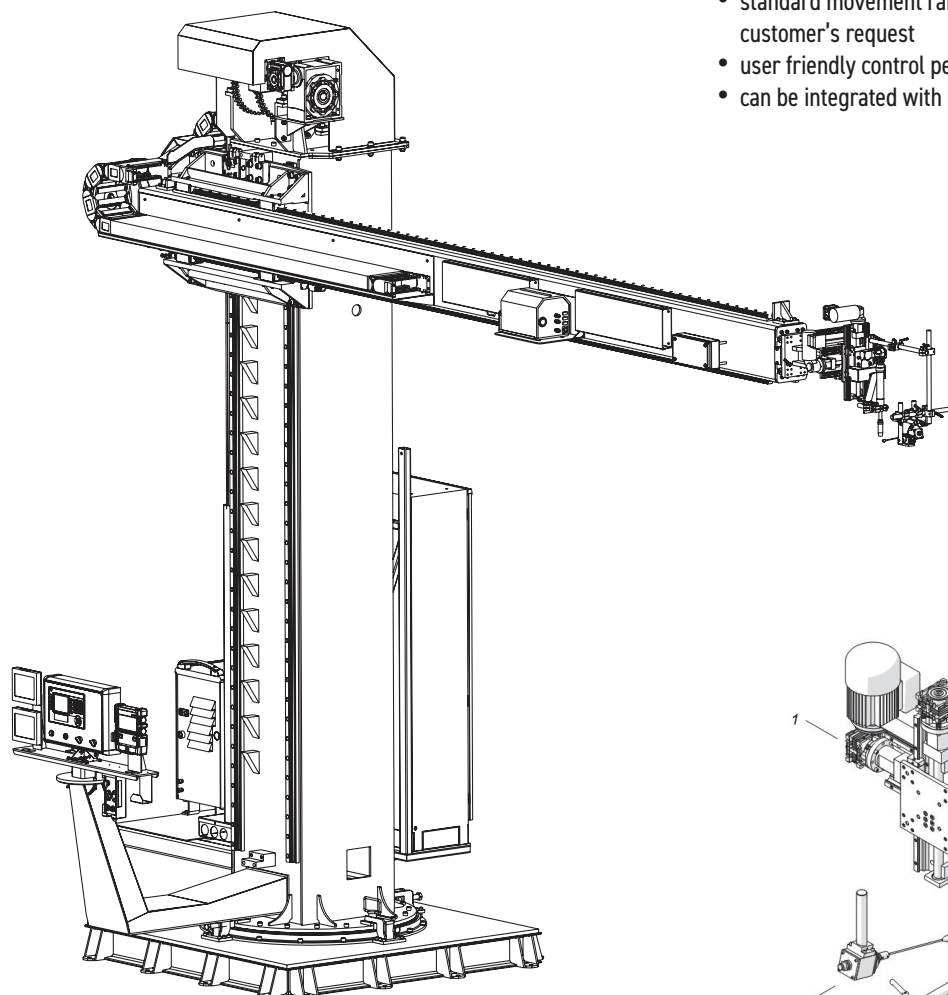


## Benefits:

- JTS is ideal for fillet and butt welding on tanks, vessels, and construction beams
- electro-mechanical joint tracking system with high-precision linear guides ensures precise and smooth motion of 2 axes (up-down and right-left)
- real-time compensation of head position relative to the welding groove
- possibility to track only in one Z-axis (up-down) useful for butt welding
- minimized welding defects and grinding
- standard movement range of 200 x 200mm to be customized upon customer's request
- user friendly control pendant
- can be integrated with pendulum oscillator OSC-8 PRO

## Standard shipping set:

1. cross slide - 1 pc
2. tracking sensor - 1 pc
3. sensor mounting set - 1 pc
4. control cabinet - 1 unit
5. sensor rod with a ball tip - 3 pcs
6. sensor rod with a bent tip - 2 pcs
7. sensor rod with a fork tip - 2 pcs
8. adapter - 3 pcs
9. control pendant - 1 pc

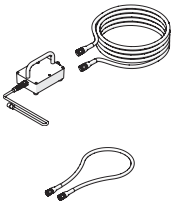


**OSC-8 PRO configurations:**

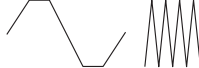
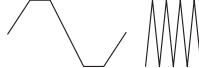
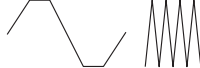
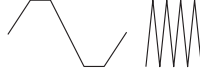
The OSC-8 PRO can be used in conjunction with a range of external equipment to create more advanced welding systems with a variety of power supplies, available operating modes and achievable weld paths (see table below).

 for technical data and accessories see page 32	<b>GECKO</b> <b>RAIL BULL</b> <b>RAIL TUG</b> PRO-WP 150, PRO-WP 300 PRO-WP 300P, PRO-WP 750P Torch stands	GECKO Battery 2 RAIL TITAN	SCORPIO Battery	RAIL TITAN 2 WA Compact SWSO
---	---	-------------------------------	-----------------	------------------------------------


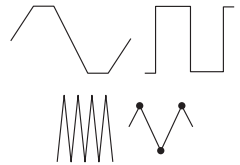
**Power supply method**

	External Power Supply ZSL-0720-03-00-05-0 (230V, EU) ZSL-0720-03-00-04-0 (230 V, D) ZSL-0720-03-00-01-0 (115 V, US) PWD-0720-04-00-00-0 Cable connecting adapter 1 m for OSC-8 PRO	Directly from oscillation socket of the machine	Directly from oscillation socket of the SCORPIO Battery	Directly from oscillation socket of the machine
---	---	---	---	---

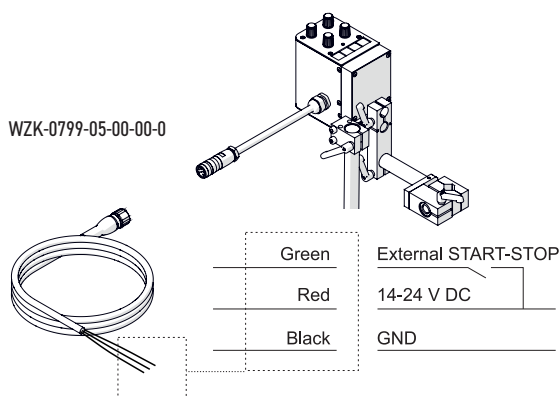
**MANUAL operation mode**

Oscillator settings:	MANUAL	MANUAL	MANUAL	MANUAL
Communication with the machine:	NO	NO	NO	NO
Weld paths:	TRAPEZOID and TRIANGLE 	TRAPEZOID and TRIANGLE 	TRAPEZOID and TRIANGLE 	TRAPEZOID and TRIANGLE 

**EXTERNAL operation mode**

Oscillator settings:	N/A	N/A	MANUAL	From remote control pendant of the machine
Communication with the machine:	N/A	N/A	YES (start/stop of both tractor & oscillator)	YES
Weld paths:	N/A	N/A	TRIANGLE and TRIANGLE with dwell times at both ends 	TRAPEZOID, SQUARE, TRIANGLE and TRIANGLE with dwell times at both ends 

OSC-8 PRO can be also integrated with external automation system:




**Product Code / Description**

**Specification**

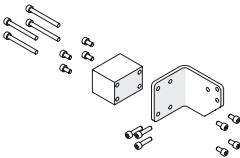
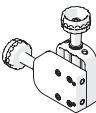
WZK-0799-05-00-00-0  
External power cable

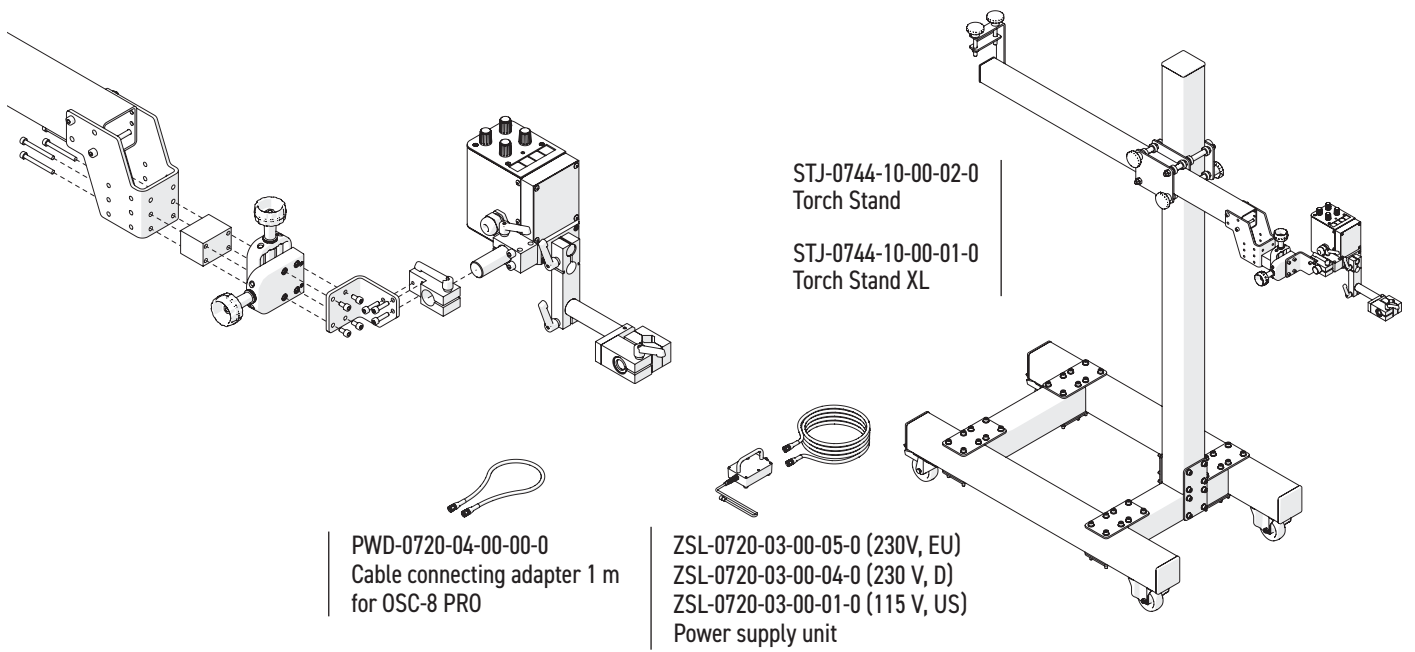
- for connecting the oscillator to an external power supply with a voltage of 14-24 V DC
- enables start/stop of OSC-8 PRO in external mode

**External operation mode**

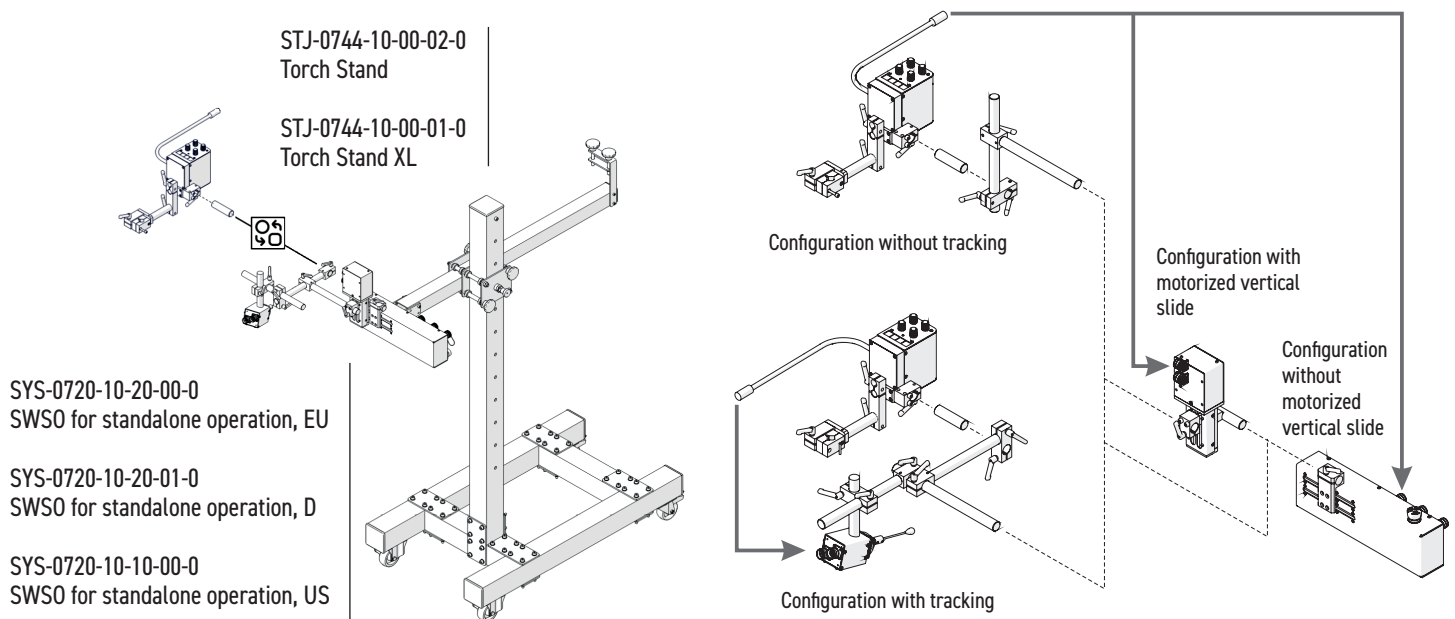
Oscillator settings:	MANUAL
Communication with external automation system:	YES (start/stop of oscillator)
Weld paths:	TRAPEZOID and TRIANGLE 

OSC-8 PRO in configuration with torch stand

Product	Product Code / Description	Specification
	ADT-0744-13-00-00-0 Cross-slide adapter for torch stand	<ul style="list-style-type: none"> <li>enables mounting of pendulum oscillator OSC-8 PRO on torch stand STJ-0744-10-00-02-0 and on torch stand XL STJ-0744-10-00-01-0</li> <li>includes: angle adapter, block adapter 50x35x40 mm, screws M5x50 (4 pcs), M5x20 (3 pcs), M5x10 (8 pcs),</li> </ul>
	ZSP-0466-14-00-00-0 Cross-slide 0-35 mm both up-down and left-right	<ul style="list-style-type: none"> <li>0-35 mm up and down adjustment</li> <li>0-35 mm left and right adjustment</li> </ul>



OSC-8 PRO in configuration with torch stand and SWSO

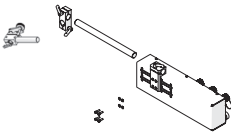
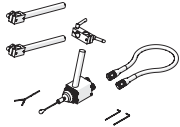
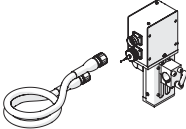


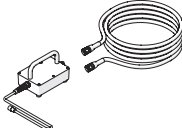
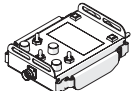


**SWSO - Circular Welding Support System**

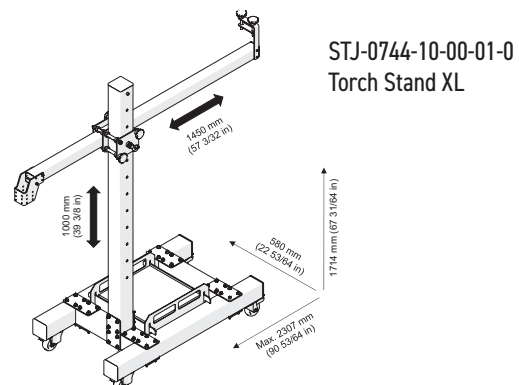
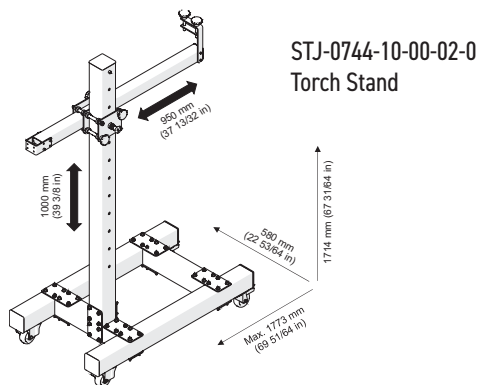
SWSO is capable of circumferential welding of pipe elements, flanges and fasteners such as elbows, tees etc.

The system is available in two essential configurations for standalone operation (3 voltage variants) and for use with the PROMOTECH Premium Positioner.

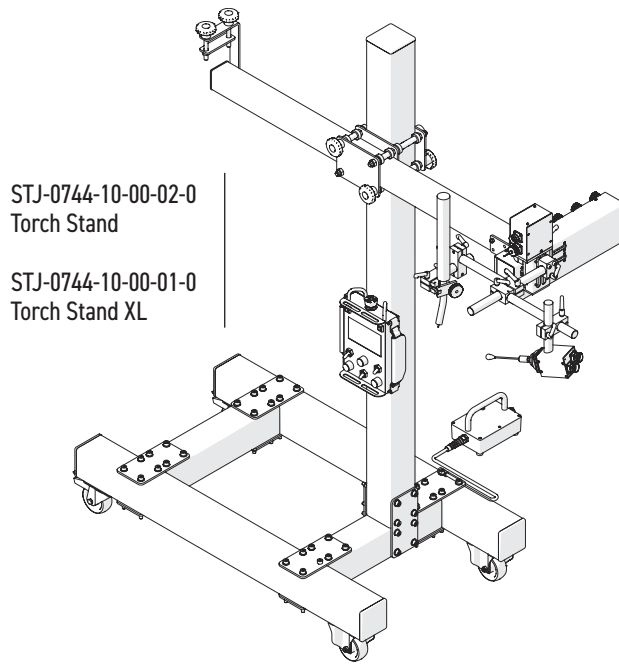
- SYS-0720-10-20-00-0 SWSO for standalone operation, plug EU
- SYS-0720-10-20-01-0 SWSO for standalone operation, plug D
- SYS-0720-10-10-00-0 SWSO for standalone operation, plug US
- SYS-0720-10-00-01-0 SWSO for use with PROMOTECH Premium Positioners

	SWSO for standalone operation			SWSO for use with PROMOTECH Premium Positioners
	EU	D	US	
 <p>OSC-0720-01-00-00-0 Linear oscillator</p>	●	●	●	●
 <p>CZJ-0654-05-00-00-0 Seam tracking attachment</p>	●	●	●	●
 <p>OSK-0654-04-00-00-0 Motorized vertical slide</p>	●	●	●	●
 <p>KBL-0466-17-00-00-0 Start-Stop arc ignition cable 6,5 m</p>	●	●	●	●
 <p>PWD-0736-30-00-00-0 Transmission cable 3 m</p>	●	●	●	●
 <p>ZSL-0720-03-00-05-0 (230V, EU) ZSL-0720-03-00-04-0 (230 V, D) ZSL-0720-03-00-01-0 (115 V, US) Power supply unit</p>	●	●	●	N/A
 <p>PNL-0736-23-00-00-0 Remote control pendant for SWSO</p>	●	●	●	N/A

The SWSO system can be equipped with either a standard or and XL torch stand, depending on customer needs.



SWSO - Circular Welding Support System for standalone operation



SYS-0720-10-20-00-0  
SWSO for standalone operation, EU

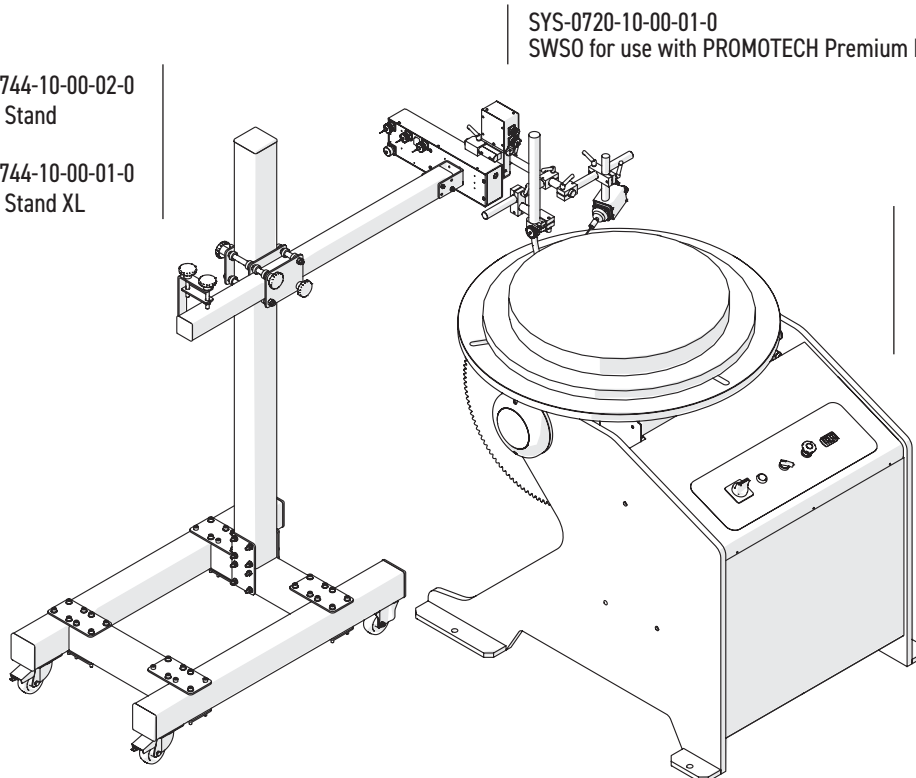
SYS-0720-10-20-01-0  
SWSO for standalone operation, D

SYS-0720-10-10-00-0  
SWSO for standalone operation, US

SWSO - Circular Welding Support System for use with PROMOTECH Premium Positioners

STJ-0744-10-00-02-0  
Torch Stand

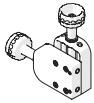

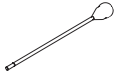



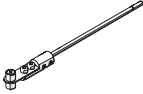
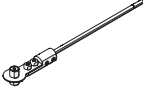
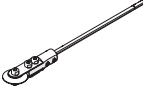
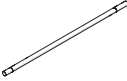


STJ-0744-10-00-01-0  
Torch Stand XL



PZY-0730-10-20-00-0  
Positioner Premium 300

PZY-0736-10-40-00-0  
Positioner Premium 750

## Auxiliary accessories:

Product	Product Code / Description	Specification
	ZSP-0466-14-00-00-0 Cross-slide 0-35 mm both up-down and left-right	<ul style="list-style-type: none"> <li>• 0-35 mm up and down adjustment</li> <li>• 0-35 mm left and right adjustment</li> </ul>
	ELM-0523-07-01-14-0 Sensor rod with a ball tip (short)	<ul style="list-style-type: none"> <li>• sensor rod 105 mm long / 3 mm OD</li> <li>• ball tip 14 mm OD</li> </ul>
	ELM-0316-06-06-00-0 Sensor rod with a ball tip (long)	<ul style="list-style-type: none"> <li>• sensor rod 210 mm long / 3 mm OD</li> <li>• ball tip 14 mm OD</li> </ul>
	PRT-0550-05-00-00-0 Sensor rod with a bent tip	<ul style="list-style-type: none"> <li>• length: 213 mm</li> </ul>
	PRT-0523-07-01-16-0 Sensor rod with a fork tip (short)	<ul style="list-style-type: none"> <li>• length: 112 mm</li> </ul>
	PRT-0550-06-00-00-0 Sensor rod with a fork tip (long)	<ul style="list-style-type: none"> <li>• length: 192 mm</li> </ul>
	ADT-0506-40-00-00-0 Sensor rod with tip I	
	ADT-0506-41-00-00-0 Sensor rod with tip II	
	ADT-0506-43-00-00-0 Sensor rod with tip IV	
	WSP-0523-07-01-13-0 Sensor rod for tips	<ul style="list-style-type: none"> <li>• length: 105 mm</li> <li>• 3 mm OD</li> </ul>
	KBL-0466-17-00-04-0 Start-Stop arc ignition cable 13 m	<ul style="list-style-type: none"> <li>• length: 13 m (42 ft)</li> <li>• 4-pin female connector (inlet)</li> <li>• 2 pairs of colour-coded wires with male and female connectors</li> <li>• enables connection of 2 welders</li> </ul>
	PWD-0736-30-00-00-0 Transmission cable 3 m	<ul style="list-style-type: none"> <li>• length: 3 m (10 ft)</li> <li>• for power supply and control</li> </ul>
	PWD-0736-30-00-01-0 Transmission cable 5 m	<ul style="list-style-type: none"> <li>• length: 5 m (16.4 ft)</li> <li>• for power supply and control</li> </ul>
	PWD-0736-30-00-02-0 Transmission cable 10 m	<ul style="list-style-type: none"> <li>• length: 10 m (32.8 ft)</li> <li>• for power supply and control</li> </ul>

PROMOTECH Sp. z o.o.  
ul. Elewatorska 23/1, 15-620 Białystok  
POLAND

Phone: +48 85 678 34 05  
marketing@promotech.eu  
www.promotech.eu

# PROMOTECH®

*smart tools for heavy tasks*

**PROMOTECH DEUTSCHLAND GmbH**  
Riedweg 11  
D-88339 Bad Waldsee/Gaisbeuren  
DEUTSCHLAND

Phone: +49 7524 9700-55  
dach@pdg.promotech.eu  
www.promotech-deutschland.de

**PROMOTECH ME (FZE)**  
P6-111, Saif Zone  
P.O. Box. 514914  
Sharjah, UAE

Phone: +9716 552 9493  
akumar@pme.promotech.eu  
www.promotechme.ae

**PROMOTECH Fabrication Machines Pvt. Ltd.**  
Head Office: Plot 231, Phase-5, Sector 53  
I/E HSIIDC Kundli, Sonipat  
Haryana-131028, INDIA

Phone: +91 966 766 0304  
info@pfm.promotech.eu  
www.promotech-india.in

**PROMOTECH ITALY**  
Via Della Resistenza, 34/F  
20090 Buccinasco (MI)  
ITALY

Phone: + 39 02 8457 1800  
davide.beltrami@ssqmotori.it  
www.promotech.eu/it/

Click the language flag or scan QR code to check the latest version of this catalogue.



Mitglied im DVS - Deutscher Verband für  
Schweißen und verwandte Verfahren e. V.



Your local dealer: